

Wash Down Duty Non-Contact Sensor

Instruction Manual

Models

WDDC1-020/040/060/080/100

WDDC2-020/040/060/080/100

WDDV1-020/040/060/080/100

WDDV2-020/040/060/080/100

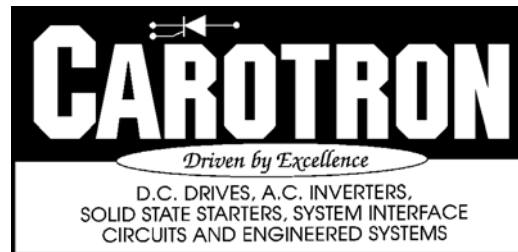

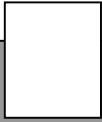

Table of Contents

1. General Description	2
2. Standard Features	2
3. Specifications & Technical Data	3
4. Installation	3
5. Adjustment Procedure	4
6. Model numbers	4
7. Prints	5
7.1 C13062 - Dimension & Wiring	5

1

General Description

The Carotron Wash Down Duty Non-Contact Sensor Models WDDC1-XXX and WDDV1-XXX (without limit switches) and WDDC2-XXX and WDDV2-XXX (with limit switches) are designed for use in harsh environments where equipment wash down, corrosion resistance and very long equipment life are important.

Our Wash Down Duty Sensor housing is constructed from stainless steel and is rated to NEMA 4X specifications. The high quality analog proximity sensor has no moving parts, senses the position of a cam and gives an output signal proportional to the angular position of the shaft. The no-maintenance bearings are made from Freelon[®], an exceptionally long life material. The stainless steel shaft is faced to aid the installation and mechanical connections. Quick release modular cabling is included with the unit and comes in five lengths ranging from 20 feet to 100 feet. This eliminates the need for connecting to terminal blocks inside the Non-Contact Sensor.

Limit switch models (WDDC2-XXX and WDDV2-XXX) contain two high quality normally closed limit switches and two adjustable cams to set extreme travel limits.

Ruggedness, superior performance, dependability, and long life characterize the Wash Down Duty Non-Contact Sensor.

Applications include:

- Dancer Position
- Rider Arm Position
- Level Sensing
- General Position Sensor

2

Standard Features

(Models WDDC1-XXX and WDDV1-XXX)

- No potentiometer to wear out
- NEMA 4X enclosure to provide protection from washing & corrosion
- Stainless Steel Construction
- External mounting feet
- Quick connect cable in 5 lengths for easy wiring
- ½-inch diameter faced sensor shaft for easy mechanical connections
- Heavy Duty bearings and seals for long life and reliability

(Models WDDC2-XXX and WDDV2-XXX)

- No potentiometer to wear out
- NEMA 4X enclosure to provide protection from washing & corrosion
- Stainless Steel Construction
- External mounting feet
- Quick connect cables in 5 lengths for easy wiring
- ½-inch diameter faced sensor shaft for easy mechanical connections
- Heavy Duty bearings and seals for long life and reliability
- Two normally closed limit switches to indicate rotational travel limit extremes
- Two adjustable cams to change counter clockwise (CCW) and (CW) limit settings

3

Specifications and Technical Data

Sensor

SPECIFICATION	MODELS WDDC1-XXX WDDC2-XXX	MODELS WDDV1-XXX WDDV2-XXX
Supply voltage	15-30 VDC	14-30 VDC
Max supply current	35 mA	20 mA
Max power rating	1.05 watts	0.6 watts
Output range	4-20 mA	1-9 VDC
Min load resistance	NA	1000 ohms
Max load resistance for 20mA output	@15 VDC = 470 ohms @25VDC = 1000 ohms	NA

Resolution: Infinite

Rotation:

Mechanical; Continuous

Electrical; 310° +/-1%

Linearity tolerance: +/-0.9%

Power Rating: <1W@30VDC input

Temperature Range: 0 - +60°C

Connections made by NEMA 4X rated connector & shielded cable (included).

Power supply inputs have reverse polarity protection and output is short circuit protected to common.

Limit Switches

(WDDC2-XXX and WDDV2-XXX only)

Ampere rating: 5 Amps

Voltage rating: 250 VAC

Connections made by a 2nd NEMA 4X rated connector & cable (included).

Enclosure

Construction: 16 ga. Stainless Steel

Finish: Mill finish gray

Industry standard: NEMA 4X

Overall Size: Box-W=4.25"; L=7.25"; H=4.4"

With Mounting Feet: L=8.39"

Mounting Hole Pattern: 2" x 7.64"

Mounting Hole diameter: 0.31"

Sensor Shaft

Construction: Stainless Steel

Diameter: ½-inch with flat

Mechanical Characteristics

Mechanical Angle: Continuous

Torque, Starting and Running:

WDD01-XXX – 3.0 oz.-in. Typical

WDD02-XXX – 6.0 oz.-in. Typical

Note: Clockwise rotation (facing shaft) gives increasing output. Output can be made "decreasing" by removing sensor cam and reversing it on the shaft.

4

Installation

Wiring Precautions

All cables should be routed away from any moving parts. Whenever possible, the sensor wiring should be routed separately from high level wiring such as armature, field, operator control and relay control wiring. When these two types of wire must cross, they should cross at right angles to each other.

Cable Connections

All models

3-wire cable:

RED: Supply, +30VDC maximum

WHITE: Output Signal

BLACK: Common

SHIELD: Common

Additional Cable for WDDC2-XXX and WDDV2-XXX

4-wire cable:

RED & WHITE: CW Limit Switch

BLACK & GREEN: CCW Limit Switch

Grounding

If grounding is required, connect a ground wire under one of the mounting screws.

Mechanical

The dancer shaft on all models is ½-in diameter. It is designed for set screw type connecting drives.

5

Adjustment Procedure

Model WDDC1-XXX and WDDV1-XXX:
No internal adjustments are required for these models. When the faced side of the sensor shaft is in the upward position, the potentiometer is factory set for approximately 50% output.

Model WDDC2-XXX and WDDV2-XXX:
The only adjustments required for these models are the settings for the extreme travel limits. When the faced side of the sensor shaft is in the upward position, the sensor is factory set for approximately half the total output range. This is referred to as the midpoint. Rotating the sensor shaft approximately 160° in the CCW direction from the midpoint will open the CCW limit contacts (black & green wires). Rotating the sensor shaft approximately 160° in the CW direction from the midpoint will open the CW limit contacts (red & white wires).

If factory set points for the extreme travel limit switches are not desirable, they are easily changed. To change the CCW limit switch set point, loosen the set screw for the CCW cam and rotate the shaft until it is in the proper position for the limit switch to activate. Limit switch activation is determined for the CCW switch by checking continuity between the black and green wires on the limit switch cable. For the CW limit switch, check continuity between the red and white wires.

Tighten the set screw and test. Repeat as needed making minor adjustments to fine tune the final opening position.

Repeat for the CW limit switch set point.

6

Model Numbers

WDDC1-020 Wash Down Duty Non-Contact Sensor, Current Output, 20 FT Cable, No Limit switches
WDDC1-040 Wash Down Duty Non-Contact Sensor, Current Output, 40 FT Cable, No Limit switches
WDDC1-060 Wash Down Duty Non-Contact Sensor, Current Output, 60 FT Cable, No Limit switches
WDDC1-080 Wash Down Duty Non-Contact Sensor, Current Output, 80 FT Cable, No Limit switches
WDDC1-100 Wash Down Duty Non-Contact Sensor, Current Output, 100 FT Cable, No Limit switches
WDDC2-020 Wash Down Duty Non-Contact Sensor, Current Output, 20 FT Cable, w/ 2 adj. limit switches
WDDC2-040 Wash Down Duty Non-Contact Sensor, Current Output, 40 FT Cable, w/ 2 adj. limit switches
WDDC2-060 Wash Down Duty Non-Contact Sensor, Current Output, 60 FT Cable, w/ 2 adj. limit switches
WDDC2-080 Wash Down Duty Non-Contact Sensor, Current Output, 80 FT Cable, w/ 2 adj. limit switches
WDDC2-100 Wash Down Duty Non-Contact Sensor, Current Output, 100 FT Cable, w/ 2 adj. limit switches
WDDV1-020 Wash Down Duty Non-Contact Sensor, Voltage Output, 20 FT Cable, No Limit switches
WDDV1-040 Wash Down Duty Non-Contact Sensor, Voltage Output, 40 FT Cable, No Limit switches
WDDV1-060 Wash Down Duty Non-Contact Sensor, Voltage Output, 60 FT Cable, No Limit switches
WDDV1-080 Wash Down Duty Non-Contact Sensor, Voltage Output, 80 FT Cable, No Limit switches
WDDV1-100 Wash Down Duty Non-Contact Sensor, Voltage Output, 100 FT Cable, No Limit switches
WDDV2-020 Wash Down Duty Non-Contact Sensor, Voltage Output, 20 FT Cable, w/ 2 adj. limit switches
WDDV2-040 Wash Down Duty Non-Contact Sensor, Voltage Output, 40 FT Cable, w/ 2 adj. limit switches
WDDV2-060 Wash Down Duty Non-Contact Sensor, Voltage Output, 60 FT Cable, w/ 2 adj. limit switches
WDDV2-080 Wash Down Duty Non-Contact Sensor, Voltage Output, 80 FT Cable, w/ 2 adj. limit switches
WDDV2-100 Wash Down Duty Non-Contact Sensor, Voltage Output, 100 FT Cable, w/ 2 adj. limit switches

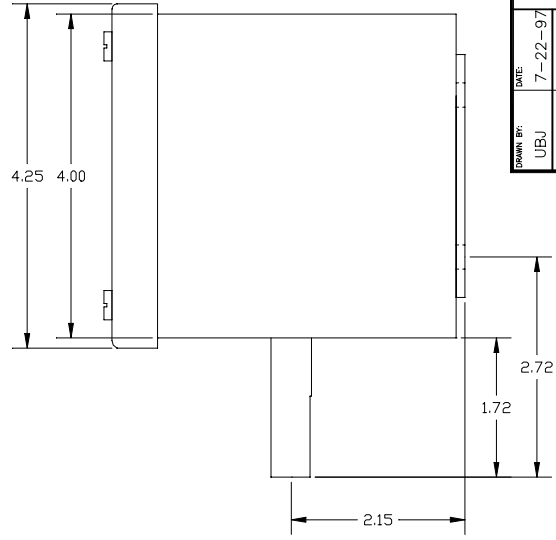
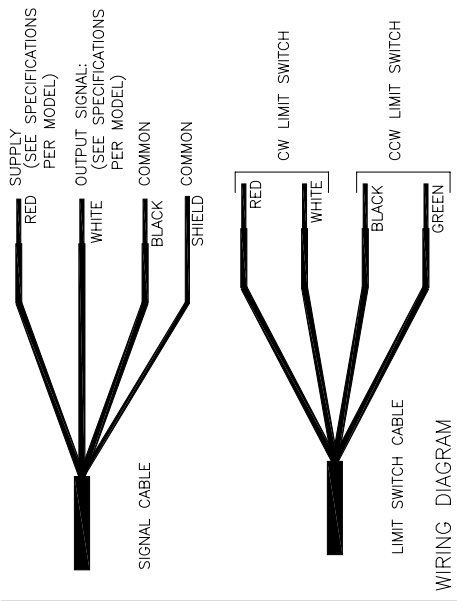

Ø0.3100 (TYP 4 PLACES)

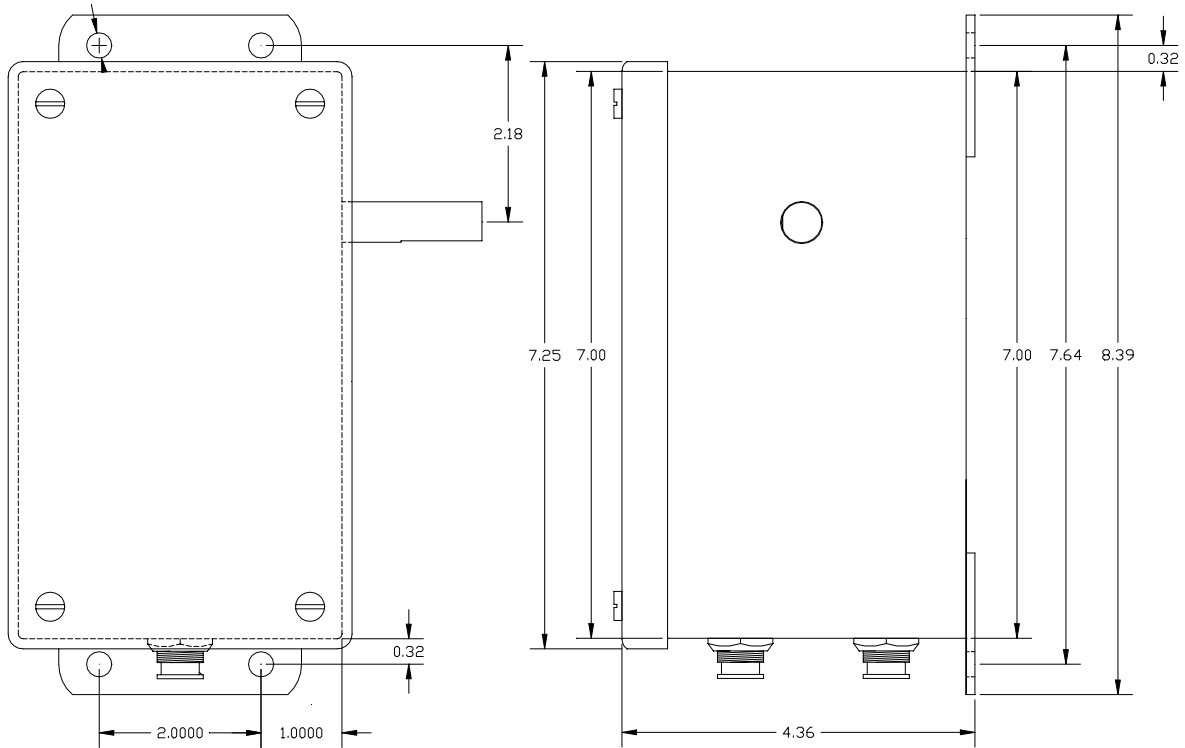

DATE:	7-22-97
DOWN BY:	UBJ
APPROVED BY:	
TOLERANCES:	4. DEC. 0.005
	3. DEC. 0.005
	2. DEC. 0.005
	1. DEC. 0.005
SCALE:	NTS
DRAWING NUMBER:	C13062
REV.	SH. 1 OF 1
<p>CAROTRON Driven by Excellence</p> <p>HEATH SPRINGS, SC TEL: 803-286-6614 FAX: 803-286-6005</p> <p>TITLE: DIMENSION & WIRING NON-CONTACT SENSOR</p>	

Standard Terms & Conditions of Sale

1. General

The Standard Terms and Conditions of Sale of Carotron, Inc. (hereinafter called "Company") are set forth as follows in order to give the Company and the Purchaser a clear understanding thereof. No additional or different terms and conditions of sale by the Company shall be binding upon the Company unless they are expressly consented to by the Company in writing. The acceptance by the Company of any order of the Purchaser is expressly conditioned upon the Purchaser's agreement to said Standard Terms and Conditions. The acceptance or acknowledgement, written, oral, by conduct or otherwise, by the Company of the Purchaser's order shall not constitute written consent by the Company to addition to or change in said Standard Terms and Conditions.

2. Prices

Prices, discounts, allowances, services and commissions are subject to change without notice. Prices shown on any Company published price list and other published literature issued by the Company are not offers to sell and are subject to express confirmation by written quotation and acknowledgement. All orders of the Purchaser are subject to acceptance, which shall not be effective unless made in writing by an authorized Company representative at its office in Heath Springs, S.C. The Company may refuse to accept any order for any reason whatsoever without incurring any liability to the Purchaser. The Company reserves the right to correct clerical and stenographic errors at any time.

3. Shipping dates

Quotation of a shipping date by the Company is based on conditions at the date upon which the quotation is made. Any such shipping date is subject to change occasioned by agreements entered into previous to the Company's acceptance of the Purchaser's order, governmental priorities, strikes, riots, fires, the elements, explosion, war, embargoes, epidemics, quarantines, acts of God, labor troubles, delays of vendors or of transportation, inability to obtain raw materials, containers or transportation or manufacturing facilities or any other cause beyond the reasonable control of the Company. In no event shall the Company be liable for consequential damages for failure to meet any shipping date resulting from any of the above causes or any other cause.

In the event of any delay in the Purchaser's accepting shipment of products or parts in accordance with scheduled shipping dates, which delay has been requested by the Purchaser, or any such delay which has been caused by lack of shipping instructions, the Company shall store all products and parts involved at the Purchaser's risk and expense and shall invoice the Purchaser for the full contract price of such products and parts on the date scheduled for shipment or on the date on which the same is ready for delivery, whichever occurs later.

4. Warranty

The Company warrants to the Purchaser that products manufactured or parts repaired by the Company, will be free, under normal use and maintenance, from defects in material and workmanship for a period of one (1) year after the shipment date from the Company's factory to the Purchaser. The Company makes no warranty concerning products manufactured by other parties.

As the Purchaser's sole and exclusive remedy under said warranty in regard to such products and parts, including but not limited to remedy for consequential damages, the Company will at its option, repair or replace without charge any product manufactured or part repaired by it, which is found to the Company's satisfaction to be so defective; provided, however, that (a) the product or part involved is returned to the Company at the location designated by the Company, transportation charges prepaid by the Purchaser; or (b) at the Company's option the product or part will be repaired or replaced in the Purchaser's plant; and also provided that (c) the Company is notified of the defect within one (1) year after the shipment date from the Company's factory of the product or part so involved.

The Company warrants to the Purchaser that any system engineered by it and started up under the supervision of an authorized Company representative will, if properly installed, operated and maintained, perform in compliance with such system's written specifications for a period of one (1) year from the date of shipment of such system.

As the Purchaser's sole and exclusive remedy under said warrant in regard to such systems, including but not limited to remedy for consequential damages, the Company will, at its option, cause, without charges any such system to so perform, which system is found to the Company's satisfaction to have failed to so perform, or refund to the

Purchaser the purchase price paid by the Purchaser to the Company in regard thereto; provided, however, that (a) Company and its representatives are permitted to inspect and work upon the system involved during reasonable hours, and (b) the Company is notified of the failure within one (1) year after date of shipment of the system so involved.

The warranties hereunder of the Company specifically exclude and do not apply to the following:

a. Products and parts damaged or abused in shipment without fault of the Company.

b. Defects and failures due to operation, either intentional or otherwise, (1) above or beyond rated capacities, (2) in connection with equipment not recommended by the Company, or (3) in an otherwise improper manner.

c. Defects and failures due to misapplication, abuse, improper installation or abnormal conditions of temperature, humidity, abrasives, dirt or corrosive matter.

d. Products, parts and systems which have been in any way tampered with or altered by any party other than an authorized Company representative.

e. Products, parts and systems designed by the Purchaser.

f. Any party other than the Purchaser.

The Company makes no other warranties or representation, expressed or implied, of merchantability and of fitness for a particular purpose, in regard to products manufactured, parts repaired and systems engineered by it.

3. Terms of payment

Standard terms of payment are net thirty (30) days from date of the Company invoice. For invoice purposed, delivery shall be deemed to be complete at the time the products, parts and systems are shipped from the Company and shall not be conditioned upon the start up thereof. Amounts past due are subject to a service charge of 1.5% per month or fraction thereof.

6. Order cancellation

Any cancellation by the Purchaser of any order or contract between the Company and the Purchaser must be made in writing and receive written approval of an authorized Company representative at its office in Heath Springs, S.C. In the event of any cancellation of an order by either party, the Purchaser shall pay to the Company the reasonable costs, expenses, damages and loss of profit of the Company incurred there by, including but not limited to engineering expenses and expenses caused by commitments to the suppliers of the Company's subcontractors, as determined by the Company.

7. Changes

The Purchaser may, from time to time, but only with the written consent of an authorized Company representative, make a change in specifications to products, parts or systems covered by a purchase order accepted by the company. In the event of any such changes, the Company shall be entitled to revise its price and delivery schedule under such order.

8. Returned material

If the Purchaser desires to return any product or part, written authorization thereof must first be obtained from the Company which will advise the Purchaser of the credit to be allowed and restocking charges to be paid in regard to such return. No product or part shall be returned to the Company without a "RETURN TAG" attached thereon which has been issued by the Company.

9. Packing

Published prices and quotations include the Company's standard packing for domestic shipment. Additional expenses for special packing or overseas shipments shall be paid by the Purchaser. If the Purchaser does not specify packing or accepts parts unpacked, no allowance will be made to the Purchaser in lieu of packing.

10. Standard transportation policy

Unless expressly provided in writing to the contrary, products, parts and systems are sold f.o.b. first point of shipment. Partial shipments shall be permitted, and the Company may invoice each shipment separately. Claims for non-delivery of products, parts and systems, and for damages thereto must be filed with the carrier by the Purchaser. The Company's responsibility therefor shall cease when the carrier signs for and accepts the shipment.



CAROTRON

Driven by Excellence

D.C. DRIVES, A.C. INVERTERS,
SOLID STATE STARTERS, SYSTEM INTERFACE
CIRCUITS AND ENGINEERED SYSTEMS

3204 Rocky River Road
Heath Springs, SC 29058
Phone: (803) 286-8614
Fax: (803) 286-6063
Email: saleserv@carotron.com
Web: www.carotron.com
MAN1046-0A
Issued 11-05-2004