

# Precision Bipolar Isolation Card

**Instruction Manual**  
**Model D10562-000**

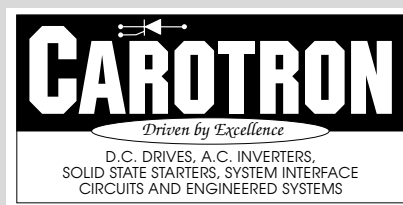

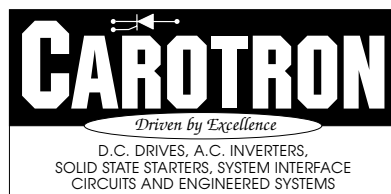

3204 Rocky River Road  
Heath Springs, SC 29058  
Phone: (803) 286-8614  
FAX: (803) 286-6063



# Table of Contents

<b>1. General Description . . . . .</b>	<b>2</b>
<b>2. Specifications . . . . .</b>	<b>2</b>
<b>3. Description of Jumpers &amp; Potentiometers . . . . .</b>	<b>3</b>
<b>4. Adjustment Procedure. . . . .</b>	<b>3</b>
4.1 Load Cell Input. . . . .	4
4.1.1 Strain Gauge Load Cells . . . . .	4
4.1.2 LVDT Load Cells . . . . .	4
4.2 Bipolar Input - Bipolar Output . . . . .	5
4.3 Bipolar Input - Unipolar Output . . . . .	5
4.4 Unipolar Input - Bipolar Output . . . . .	5
4.5 Unipolar Input - Unipolar Output . . . . .	5
4.6 Adjusting Output for Low Input . . . . .	6
4.7 Outputs Greater than 12VDC up to 24VDC. . . . .	6
<b>5. Prints. . . . .</b>	<b>7</b>
5.1 C10563 - Dimension . . . . .	7
5.2 C10560 - Schematic . . . . .	8
5.3 D10562 -Assembly . . . . .	9
5.4 D10564-S1 - Connection . . . . .	10
5.5 D10564-S2 - Connection . . . . .	11

# 1 General Description

Model D10562-000 Precision Bipolar Isolation card is designed for applications where signal conditioning is required in a single channel, while maintaining electrical isolation between input and output signals. Designed for a wide variety of input signals, model D10562-000 can accept the following types of inputs:

- Potentiometer
- D.C. Voltage
- Load Cell (Strain Gauge & LVDT type)
- Current Shunt

Each input signal is conditioned by scaling circuits which can be modified via on board multi-turn OFFSET, GAIN and BIAS potentiometers.

Terminal strip connections are provided for a trim potentiometer, auxiliary input, summing input and meter output. A single turn TRIM RANGE adjustment is provided to limit the range of the external trim potentiometer. Also a METER RANGE adjustment is provided to limit the range of the meter output. The output circuit can be configured to source either a voltage or a current. Typical output ranges are: -10 to +10VDC, 0 to 20mADC, or 4 to 20mADC.

The card can also be calibrated to give an inverted logic output (increasing input causes decreasing output), extended gain for low level input signals and also extended output voltages (greater than 12VDC).

# 2 Specifications

## AC Input

- 115/230 VAC  $\pm 10\%$ , 50/60 Hz, internally fused at .3AMPS.

## Isolation Voltage

- 2400V PEAK AT 1 SECOND OR 1500 VRMS

## Linearity

- $\pm 0.1\%$  of 10 VDC span

## Signal Inputs

- Potentiometer Input  
 $\pm 5$ VDC available to source a 500 to 10,000 Ohm potentiometer. The 10VDC input range should be selected for this type of input.
- Voltage Input  
7 selectable ranges with 100K to 10M Ohm input impedance.

Input Range	Input Impedance
-100mVDC to +100mVDC	100K
-1VDC to + 1VDC	1M
-2.5VDC TO +2.5VDC	100K
-10VDC TO +10VDC	10M
-25VDC TO +25VDC	1M
-100VDC TO +100VDC	10M
-250VDC TO +250VDC	10M

- Load Cell Input  
4 selectable multiplier ranges with 10G Ohm input impedance.  $\pm 5$ VDC available for excitation voltage capable of sourcing 75mA.
- Trim Potentiometer Input  
Allows connection of an external 10,000 Ohm potentiometer to trim the output. The

trim range may be as wide as  $-100\%$  or limited to 80 to 100%.

- Auxiliary Input  
This allows a fixed or variable signal (-10VDC to +10VDC) to be summed directly with the scaled input signal. The polarity may be inverted by selecting (-) on J6. Isolation is maintained between the auxiliary input and the output.
- Summing Input  
This input allows a fixed or variable signal (-10VDC to +10VDC) to be summed directly (gain of 1) with the output. the polarity may be inverted by selecting (-) on J7. Isolation is not maintained between the summing input and the output.

## Output Types

- Voltage Output  
Selected by position V on jumper J8. This circuit allows the output to source a  $\pm 12$ VDC voltage level into a minimum resistance of 500 Ohms. At low output load currents and with special connections, output voltages up to 24VDC can be sourced.
- Current Output  
Selected by position 1 on Jumper J8. This circuit allows the output to source a regulated current of up to 20mAmps into a maximum resistance of 500 Ohms. Using the BIAS potentiometer, the output can source a 4 to 20mAmp signal.

# 3 Description of Jumpers and Potentiometers

## J1

Selects between the Normal Voltage input circuit or the Load Cell input circuit.

## J2

Selects between the 3 multiplier ranges: .01, .1, or 1.

## J3

Selects between the 3 Voltage input range maximums: 10V, 100V, or 250V.

NOTE: the actual voltage range is determined from the range maximums at J3 times the multiplier at J2.

## J5

Selects between the 4 multiplier ranges of the strain gauge type Load Cell input: 1, 10, 100, or 1000.

## J6

Selects the function, addition (+) or subtraction (-), to be performed by the Auxiliary input.

## J7

Selects the function, addition (+) or subtraction (-), to be performed by the Summing input.

## J8

Selects the Output Mode between Voltage or Current. Position V on J7 selects the voltage Mode and the output is sourced from TB2-13 and 14. Position I on J7 selects the Current Mode and the output is sourced from TB2-13 and 15.

## Offset Potentiometer

Used to zero out or offset input signals as required for bipolar or unipolar operating modes.

This pot provides the "TARE" function when Load Cells are used.

## Gain Potentiometer

Used to set the maximum output level.

## Bias Potentiometer

Used to set the desired output level with the minimum reference input in unipolar output applications.

## Trim Potentiometer

Used to ratio the output of the first amplifier stage from 100% down to a percentage level set by the TRIM RANGE potentiometer. If a TRIM pot. is not used, Jumper TB2-19 to 20.

## Trim Range Potentiometer

Used to set the minimum percentage level for the TRIM potentiometer. Using a 10K TRIM potentiometer, the trim range can be set as wide as 0 to 100% or as narrow as 80 to 100%.

## Meter Range Potentiometer

Used to set the range of the meter output.

# 4 Adjustment Procedure

Select the type of input signal desired and use the appropriate procedure listed below. In each case, make the following selections prior to starting the adjustment procedure.

- Select the type of output desired using Jumper J8. If a Voltage output is desired, select V on Jumper J8 and use terminals TB2-13 (OUTPUT) and TB2-14 (VOLTAGE RETURN). If a Current Output is desired, select I on J8 and use TB2-13 (OUTPUT) and TB2-15 (CURRENT RETURN).

## Note:

The following procedures discuss adjusting output voltage. For UNIPO-LAR output current signal calibration, substitute "output voltage" with output current. BIPOLAR output current signals can be used only when the minimum output is adjusted for zero mA.

- If a Summing or Auxiliary Input is used, make sure this input is at zero for the following calibration adjustments.
- If a TRIM potentiometer is used, turn it to the full clockwise position. If a limited trim range is desired, preset the TRIM RANGE potentiometer per the following to approximate the range desired. If a TRIM potentiometer is not used, Jumper TB2-19 to 20.

Trim Range	10K Trim Potentiometer Pot Setting	Adjustment Range
0% clockwise		1 to 100%
25% Clockwise		55 to 100%
50% Clockwise		71 to 100%
100% Clockwise		83 to 100%

- Proceed to section 4.1 if a Load Cell is being used for input.
- Connect the voltage reference input to TB1-3 with respect to TB1-4. in accordance with drawing D10564. Select Normal on Jumper J1.
- Select the proper voltage input range on Jumpers J2 and J3 by determining the maximum input voltage ( $V_{in}$ ). Select the lowest input range which is greater than or equal to  $V_{in}$ .

J2 Selection	J3 Selection	Voltage Range
X1	10V	$\pm 10V$
X.1	10V	$\pm 1V$
X.01	10V	$\pm 100mV$
X1	100V	$\pm 100V$
X1	250V	$\pm 250V$
X.1	250V	$\pm 25V$
X.01	250V	$\pm 2.5V$

## 4.1 Load Cell Input

Two different types of load cells, strain gauge and LVDT can be used with this product. The output of strain gauge cells must be amplified and will connect to the instrumentation amplifier input at TB1 terminals 8 and 10. LVDT type cells have a pre-amplified output and must be connected to the voltage input at TB1 terminals 3 and 4. The OFFSET pot is used for the "TARE" function for both types of load cells.

## 4.1.1 Strain Gauge Load Cells

- Connect the Load Cell/Cells per drawing D10564. Select LOAD CELL on Jumper J1.
- Determine the maximum output of the load cell and select the proper multiplier (1, 10, 100, or 1000) at J5 which will result in the highest voltage level not greater than  $\pm 10VDC$ . Select the lowest input range at Jumpers J2 and J3 which is greater than or equal to this determined value.
- Proceed to Section 4.2, 4.3, 4.4 or 4.5 depending on the type of polarity of the input and output signals.

## 4.1.2 LVDT Load Cell Input

The LVDT load cell shown in drawing D10564 has color coded wires for the connections. Red is for the +5VDC input, Black is the power supply common, and Green & Yellow are the load cell output. For normal loading on the cell, a positive output is achieved with the Green wire tied to the input at TB1-3 and Yellow tied to the input common at TB1-4. A negative output can be achieved by reversing the connections of the Green and Yellow wires.

For the single cell input, the normal gain range of the output circuit is not high enough to allow for 10VDC output at TB2 terminals 13 and 14 with full load on the cell. The connection shown between TB2-16 (Summing Input) and TB2-20 (Trim Pot Wiper) with jumper J7=(-), doubles the range of the gain circuit. Refer to drawing D10564, INCREASED GAIN OUTPUT. The meter output at TB2-18 has a 2:1 amplification so this circuit can normally achieve a 10VDC output with a single cell input.

For the dual cell input, the load cell connections shown make use of the tie point terminal TB1-9 to put the load cells in series to add the output levels together. Depending on the TARE level, the gain circuit can normally supply enough range for 10VDC output without a connection between TB2-16 and TB2-20. If however, the TARE is too high or the cells are not fully

loaded for the required 10VDC output, this connection can be used to supply additional gain range. Remember to set Jumper J7=(-) also.

- Connect the Load Cell/Cells per drawing D10564. Select J1=NORMAL, J2=X0.1, J3=10. This provides for a normal voltage input with a range of 1 VDC maximum.
- The J5 Jumper is not used. If an Auxiliary Input is necessary, place J6 in the position appropriate to desired function.
- Place a jumper between TB2-19 and 20 if a Trim pot is not used.
- Proceed to Section 4.2, 4.3, 4.4, or 4.5 for final adjustment steps.

## 4.2 Bipolar Input-Bipolar Output

This section will aid in setting up the Precision Bipolar Isolation Card to receive positive and negative reference signals and to source positive and negative signals at the output terminal.

- With the reference input at zero or minimum level, apply power to the Precision Bipolar Isolation Card. Turn the GAIN potentiometer full clockwise (approximately 15 turns). Adjust the OFFSET potentiometer for 0.0VDC between TB2-19 and TB2-17. Turn the GAIN potentiometer full counter clockwise (CCW).
- Adjust the Bias potentiometer for 0.0VDC at TB2-13 and TB2-14. Apply the full positive or negative reference input voltage. Adjust the GAIN potentiometer for the maximum positive or negative output. If a meter is connected at TB2 terminals 17 and 18, adjust the Meter Range pot to set the meter to the desired level.
- The unit is now calibrated for operation. the output level relative to the input signal may now be trimmed by the TRIM potentiometer or external signals may be summed using the Summing and Auxiliary Inputs.

## 4.3 Bipolar Input-Unipolar Output

This section will aid in setting up the Precision Bipolar Isolation Card to receive positive and negative reference signals and to source a positive or negative signal at the output terminal.

- Apply power to the Precision Bipolar Isolation Card. Turn the GAIN potentiometer full clockwise (approximately 15 turns). Apply the maximum negative reference input. Adjust the OFFSET potentiometer for 0.0VDC between TB2-19 and TB2-17. Turn the GAIN potentiometer full counter clockwise (CCW).
- Adjust the BIAS potentiometer for the minimum output level desired at TB2-13 and TB2-14 with maximum negative input. Apply the full positive reference input voltage. Adjust the GAIN potentiometer for the maximum desired output. If a meter is connected at TB2 terminals 17 and 18, adjust the Meter Range pot to set the meter to the desired level.
- The unit is now calibrated for operation. The output level relative to the input signal may now be trimmed by the TRIM potentiometer or external signals may be summed using the Summing and Auxiliary Inputs.

## 4.4 Unipolar Input-Bipolar Output

This section will aid in setting up the Precision Bipolar Isolation Card to receive positive or negative reference signals and to source positive and negative signals at the output terminal.

- Apply power to the Precision Bipolar Isolation Card. Turn the GAIN potentiometer full clockwise (approximately 15 turns). Apply 50% input reference and adjust the OFFSET potentiometer for 0.0VDC between TB2-19 and TB2-17. Turn the GAIN potentiometer full counter clockwise (CCW).
- Adjust the Bias potentiometer for 0.0VDC at TB2-13 and TB2-14. Apply the full positive or negative reference input voltage. Adjust the GAIN potentiometer for the maximum positive or negative output at TB2-13 and TB2-14. If a meter is connected at TB2 terminals 17 and 18, adjust the Meter Range pot to set the meter to the desired level. Returning the input to zero should result in a voltage level equal to that at maximum input but opposite in polarity.
- The unit is now calibrated for operation. The output level relative to the input signal may now be trimmed by the TRIM potentiometer or external signals may be summed using the Summing and Auxiliary Inputs.

## 4.5 Unipolar Input- Unipolar Output

This section will aid in setting up the Precision Bipolar Isolation Card to receive positive or negative reference signals and to source a positive or negative signal at the output terminal.

- With the reference input at zero volts or with minimum load cell force, apply power to the Precision Bipolar Isolation Card. Turn the GAIN potentiometer full clockwise (approximately 15 turns). Adjust the OFFSET potentiometer for 0.0VDC between TB2-19 and TB2-17. Turn the GAIN potentiometer full counter clockwise (CCW).
- Adjust the Bias potentiometer for the minimum output level desired at TB2-13 & 14 with minimum reference input. Apply the full positive or negative reference input voltage or maximum force on the load cell(s). Adjust the GAIN potentiometer for the maximum output. If a meter is connected at TB2 terminals 17 and 18, adjust the Meter Range pot to set the meter to the desired level.
- The unit is now calibrated for operation. The output level relative to the input signal may now be trimmed by the TRIM potentiometer or external signals may be summed using the Summing and Auxiliary Inputs.

## 4.6 Adjusting Output for Low Input

When low level inputs are used, the gain circuit may not be able to supply enough range to achieve the desired 10VDC or 20mA outputs. In these cases, the Summing Input can be used to double the output range. This is done by placing a jumper between TB2 terminals 16 & 20 and setting jumper J7=(-). The output can now be set up by following the instructions in Section 4.2, 4.3, 4.4 or 4.5, depending on the type of polarity of the input and output signals.

NOTE: The output is still limited to 12VDC or 20mA.

## 4.7 Outputs greater than 12VDC up to 24 VDC

When the BIAS and OFFSET pots are both set at 0, the voltage at TB2-19 is opposite in polarity, but equal in magnitude to TB2-1. This can be used to achieve an output signal up to 24VDC (5mA maximum current). Refer to drawing D10564, 24VDC OUTPUT. This is achieved by making TB2-20 the common of the voltage receiver and using TB2-1 as the reference.



# 5

# Prints

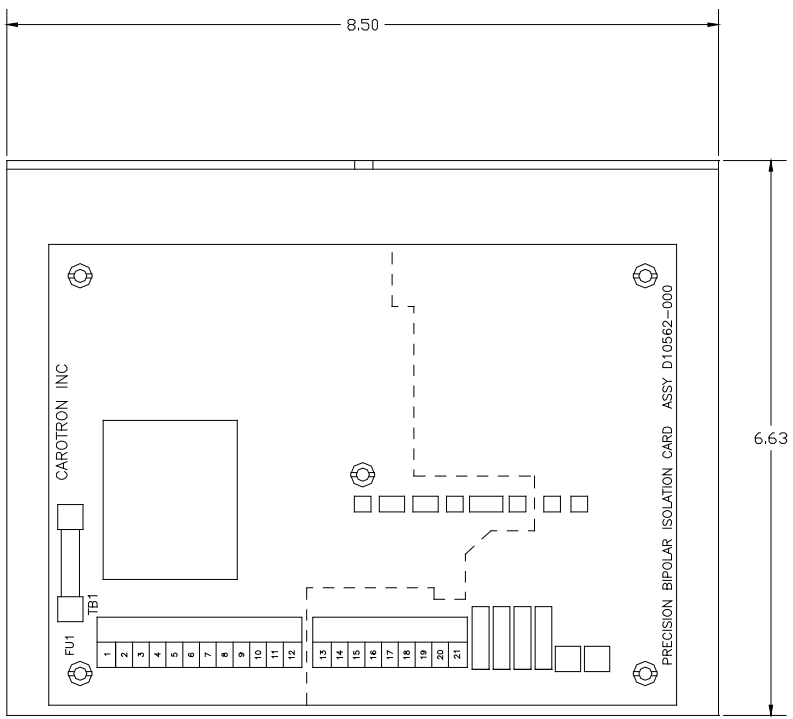
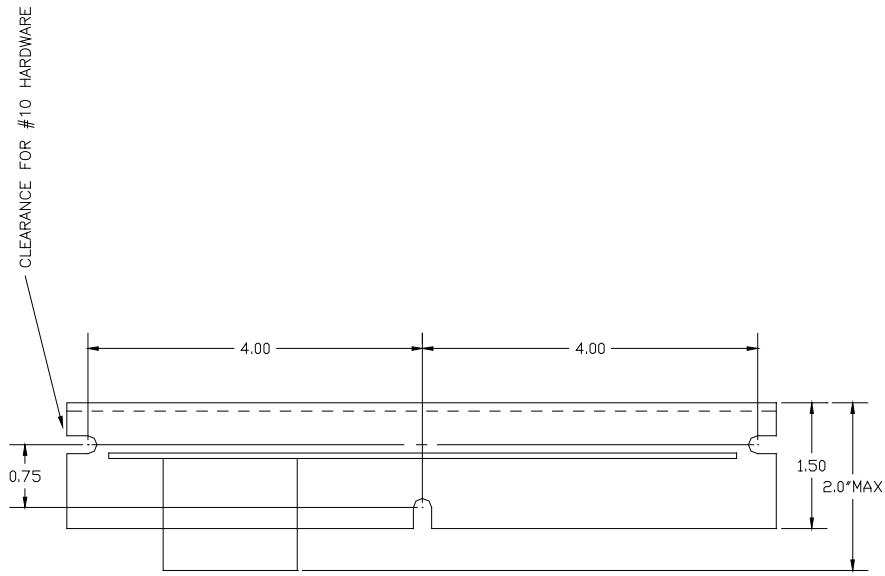

DRAWN BY: <b>FJH</b>	DATE: 7-25-90	 Driven by Excellence
APPROVED BY:	DATE:	
TOLERANCES: ± 2 DEC. PL. 3 DEC. PL.		HEATH SPRINGS, SC TEL 803-286-8674 FAX 803-286-8063
SCALE: ---		TITLE: DIMENSION DIAGRAM BIPOLAR ISOLATION CARD
DRAWING NUMBER: <b>C10563</b>		REV. SH. 1 OF 1

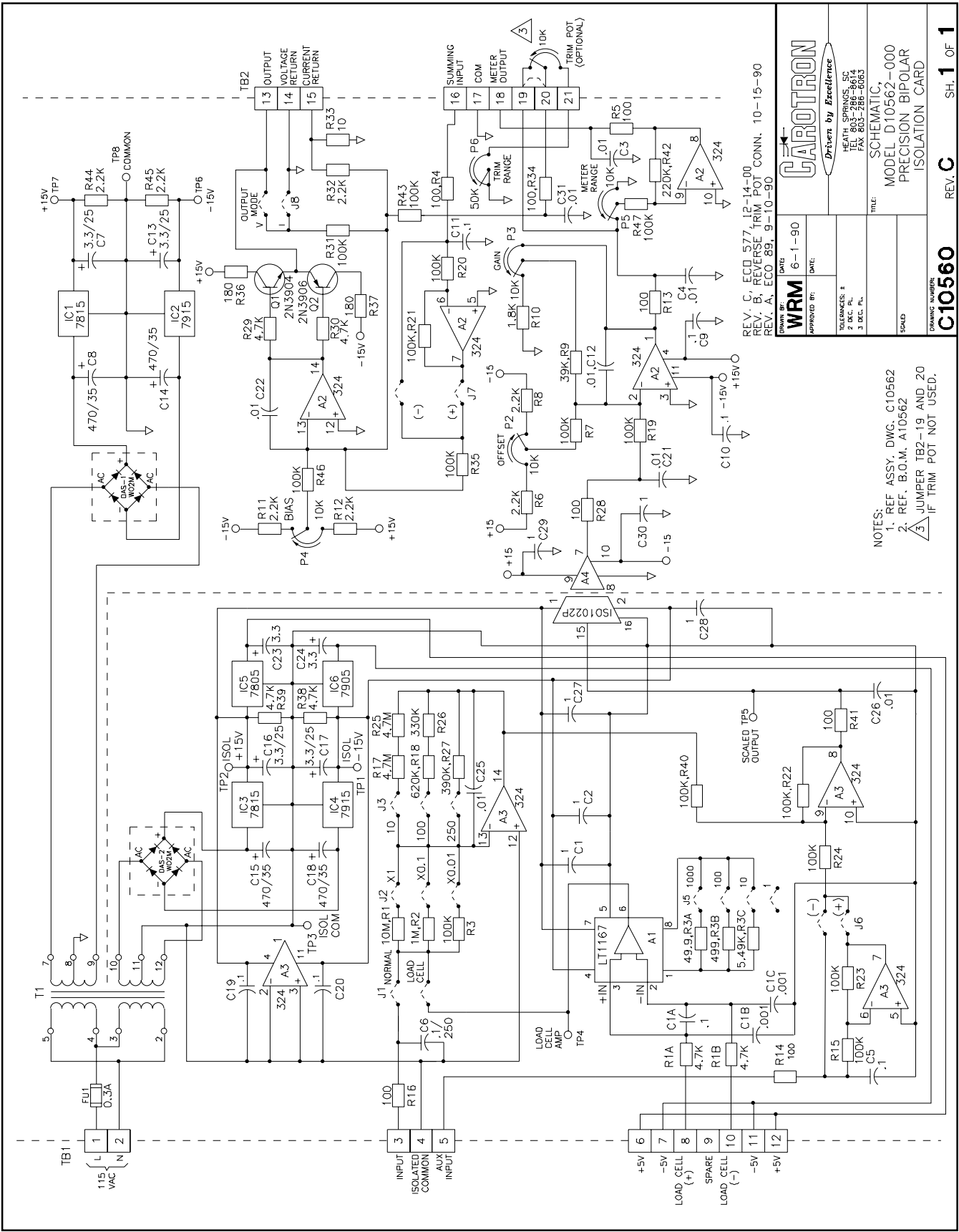

REV. C: ECO 577, 12-14-90  
 REV. B: REVERSE TRIM POT CONN. 10-15-90  
 REV. A: ECO 89, 9-10-90

DATE: 6-1-90  
 APPROVED BY: WRM



HEATH SPRINGS, SC  
 2 DEC. PL.  
 3 DEC. PL.  
 FAX: 803-286-6643

TITLE: SCHEMATIC,  
 MODEL D10562-000  
 PRECISION BIPOLAR  
 ISOLATION CARD

DRAWING NUMBER: C10560  
 REV. C  
 SH. 1 OF 1

- NOTES:
1. REF ASSY. DWG. C10562
  2. REF. B.O.M. A10562
  3. JUMPER TB2-19 AND 20 IF TRIM POT NOT USED.

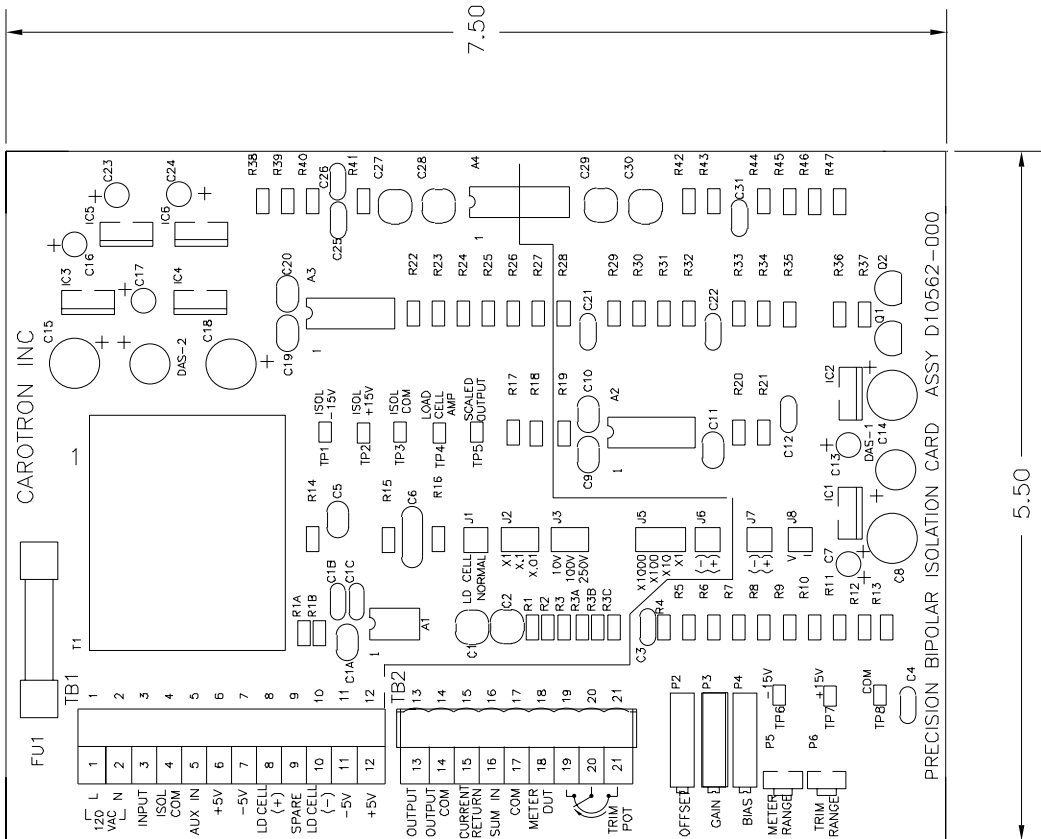

NOTES:  
 1. REF. SCHEM. DWG. C10560  
 2. REF. B.O.M. A10562

REV. B, ECO 577, 1-2-01  
 REV. A, ECO 89, 9-11-90

DATE: 7-13-90	BY: WRM
APPROVED BY:	
<b>CAROTRON</b> <i>Direct by Excellence</i>	
HEATH SPRINGS, SC P.O. BOX 288 4 SOC. PL.	
TITLE: ASSY. D10562-000 PRECISION BIPOLAR ISOLATION CARD.	
SCALE:	
DRAWING NUMBER: <b>D10562</b> REV. <b>B</b> SH. <b>1</b> OF <b>1</b>	

GENERAL CONNECTIONS

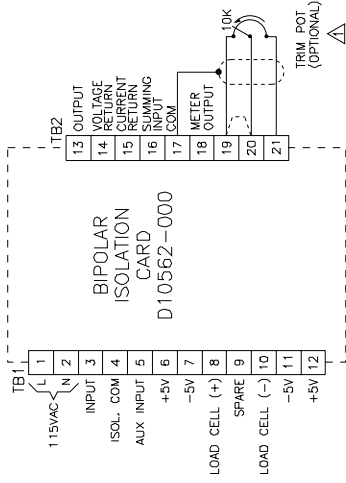

BI-POLAR POTENTIOMETER INPUT

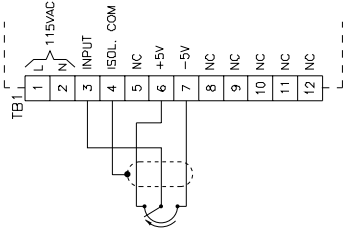

JUMPER SETTINGS:  
 J1=NORMAL  
 J2=x1  
 J3=10V  
 J6=PER APPLICATION

DUAL LVDT LOAD CELL INPUT

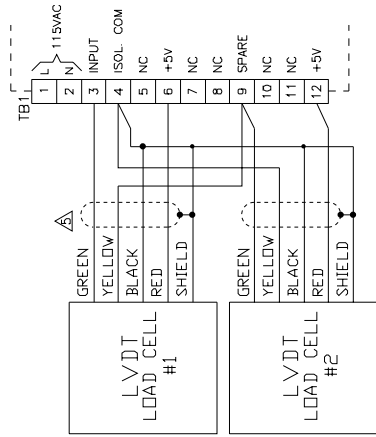

JUMPER SETTINGS:  
 J1=NORMAL  
 J2=x1  
 J3=10V  
 J6=PER APPLICATION

SINGLE LVDT LOAD CELL INPUT

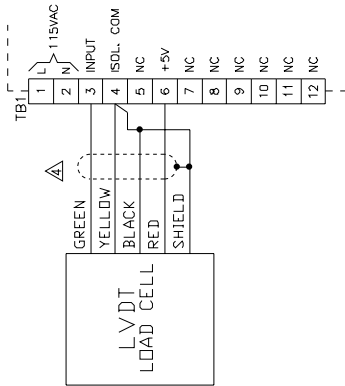

JUMPER SETTINGS:  
 J1=NORMAL  
 J2=x0.1  
 J3=10V  
 J6=PER APPLICATION

SINGLE STRAIN GAUGE BRIDGE LOAD CELL INPUT

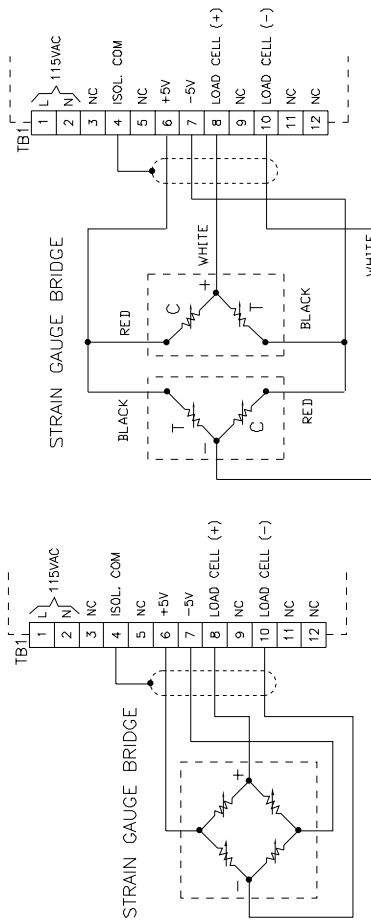

JUMPER SETTINGS:  
 J1=LOAD CELL VOLTAGE INPUT  
 J2=PER INPUT VOLTAGE  
 J3=PER INPUT VOLTAGE  
 J5=PER INPUT VOLTAGE  
 J6=PER APPLICATION

DUAL STRAIN GAUGE BRIDGE LOAD CELL INPUT

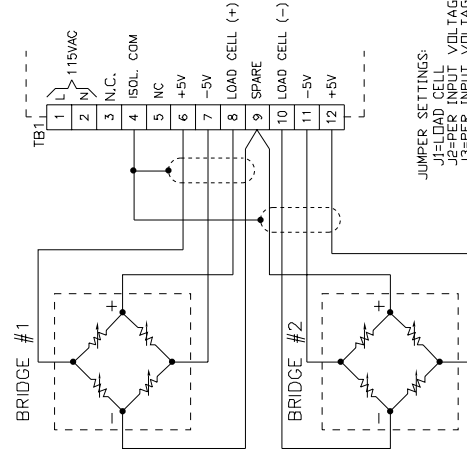

JUMPER SETTINGS:  
 J1=LOAD CELL VOLTAGE INPUT  
 J2=PER INPUT VOLTAGE  
 J5=PER INPUT VOLTAGE  
 J6=PER APPLICATION

NOTES:

- 1. JUMPER TB2-19 TO TB2-20 IF TRIM POT IS NOT USED.
- 2. REF. SCHEMATIC C10560 AND ASSEMBLY D10562.
- 3. REFER TO MANUAL FOR PROGRAMING AND ADJUSTMENTS.
- 4. EXCHANGE CONNECTION OF GREEN ON LOAD CELL WITH YELLOW ON LOAD CELL TO REVERSE OUTPUT POLARITY.
- 5. EXCHANGE CONNECTION OF GREEN ON LOAD CELL #1 WITH YELLOW ON LOAD CELL #2 TO REVERSE OUTPUT POLARITY.
- 6. DO NOT USE SUMMING INPUT WITH THIS CONFIGURATION.

REV. C, ESD 577, 1-5-01  
 REV. B, ADD LVDT CONNECTIONS, 10-12-95  
 REV. A, REVERSE TRIM POT CONN., 10-15-90

Part # **HJH** 8-3-90  
 DATE: 8-3-90

DESIGNED BY: **Gartron**  
 DRAWN BY: **Gartron**  
 CHECKED BY: **Gartron**  
 APPROVED BY: **Gartron**

CONNECTION DIAGRAM  
 BIPOLAR ISOLATION CARD  
 D10562-000

DRAWING NAME: **D10562** REV. **C** SH. **1** OF **2**

### VOLTAGE OUTPUT

(0 TO 12VDC)

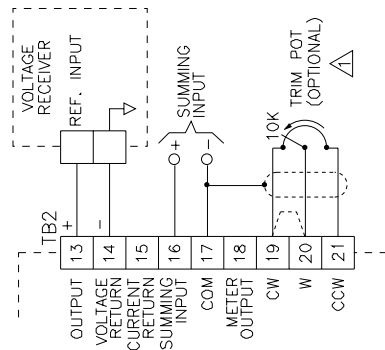

JUMPER SETTINGS:  
J7=PER APPLICATION  
J8=V

### CURRENT OUTPUT

(0 TO 20mA)

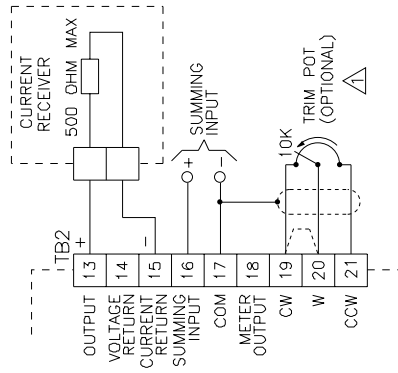

JUMPER SETTINGS:  
J7=PER APPLICATION  
J8=1

### INCREASED GAIN OUTPUT

(0 TO 12VDC OR 0 TO 20mA)

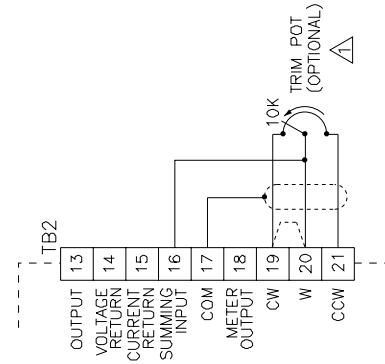

JUMPER SETTINGS:  
J7=(-)  
J8=PER APPLICATION

### 24VDC OUTPUT

(0 TO 5mA)

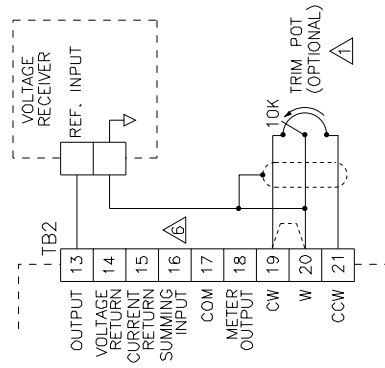

JUMPER SETTINGS:  
J8=V

- NOTES:
- JUMPER TB2-19 TO TB2-20 IF TRIM POT IS NOT USED.
  - REF. SCHEMATIC C1050 AND ASSEMBLY D1052.
  - REFER TO MANUAL FOR PROGRAMMING AND ADJUSTMENTS.
  - EXCHANGE CONNECTION OF GREEN ON LOAD CELL WITH YELLOW ON LOAD CELL TO REVERSE OUTPUT POLARITY.
  - EXCHANGE CONNECTION OF GREEN ON LOAD CELL #1 WITH YELLOW ON LOAD CELL #2 TO REVERSE OUTPUT POLARITY.
  - DO NOT USE SUMMING INPUT WITH THIS CONFIGURATION.

REV. C, ECD 577, 1-5-01  
REV. B, ADD LVDT CONNECTIONS, 10-12-95  
REV. A, REVERSE TRIM POT CONN., 10-15-90

MODEL: <b>D10562</b>	PART NO.: <b>8-3-90</b>
DATE:	BY:
APPROVED BY:	DESIGNED BY:
DRAWN BY:	CHECKED BY:
DATE:	DATE:
SCALE:	REV:
CONNECTION DIAGRAM BIPOLAR ISOLATION CARD D10562-000	



# Standard Terms & Conditions of Sale

## 1. General

The Standard Terms and Conditions of Sale of Carotron, Inc. (hereinafter called "Company") are set forth as follows in order to give the Company and the Purchaser a clear understanding thereof. No additional or different terms and conditions of sale by the Company shall be binding upon the Company unless they are expressly consented to by the Company in writing. The acceptance by the Company of any order of the Purchaser is expressly conditioned upon the Purchaser's agreement to said Standard Terms and Conditions. The acceptance or acknowledgement, written, oral, by conduct or otherwise, by the Company of the Purchaser's order shall not constitute written consent by the Company to addition to or change in said Standard Terms and Conditions.

## 2. Prices

Prices, discounts, allowances, services and commissions are subject to change without notice. Prices shown on any Company published price list and other published literature issued by the Company are not offers to sell and are subject to express confirmation by written quotation and acknowledgement. All orders of the Purchaser are subject to acceptance, which shall not be effective unless made in writing by an authorized Company representative at its office in Heath Springs, S.C. The Company may refuse to accept any order for any reason whatsoever without incurring any liability to the Purchaser. The Company reserves the right to correct clerical and stenographic errors at any time.

## 3. Shipping dates

Quotation of a shipping date by the Company is based on conditions at the date upon which the quotation is made. Any such shipping date is subject to change occasioned by agreements entered into previous to the Company's acceptance of the Purchaser's order, governmental priorities, strikes, riots, fires, the elements, explosion, war, embargoes, epidemics, quarantines, acts of God, labor troubles, delays of vendors or of transportation, inability to obtain raw materials, containers or transportation or manufacturing facilities or any other cause beyond the reasonable control of the Company. In no event shall the Company be liable for consequential damages for failure to meet any shipping date resulting from any of the above causes or any other cause.

In the event of any delay in the Purchaser's accepting shipment of products or parts in accordance with scheduled shipping dates, which delay has been requested by the Purchaser, or any such delay which has been caused by lack of shipping instructions, the Company shall store all products and parts involved at the Purchaser's risk and expense and shall invoice the Purchaser for the full contract price of such products and parts on the date scheduled for shipment or on the date on which the same is ready for delivery, whichever occurs later.

## 4. Warranty

The Company warrants to the Purchaser that products manufactured or parts repaired by the Company, will be free, under normal use and maintenance, from defects in material and workmanship for a period of one (1) year after the shipment date from the Company's factory to the Purchaser. The Company makes no warranty concerning products manufactured by other parties.

As the Purchaser's sole and exclusive remedy under said warranty in regard to such products and parts, including but not limited to remedy for consequential damages, the Company will at its option, repair or replace without charge any product manufactured or part repaired by it, which is found to the Company's satisfaction to be so defective; provided, however, that (a) the product or part involved is returned to the Company at the location designated by the Company, transportation charges prepaid by the Purchaser; or (b) at the Company's option the product or part will be repaired or replaced in the Purchaser's plant; and also provided that (c) the Company is notified of the defect within one (1) year after the shipment date from the Company's factory of the product or part so involved.

The Company warrants to the Purchaser that any system engineered by it and started up under the supervision of an authorized Company representative will, if properly installed, operated and maintained, perform in compliance with such system's written specifications for a period of one (1) year from the date of shipment of such system.

As the Purchaser's sole and exclusive remedy under said warrant in regard to such systems, including but not limited to remedy for consequential damages, the Company will, at its option, cause, without charges any such system to so perform, which system is found to the Company's satisfaction to have failed to so perform, or refund to the

Purchaser the purchase price paid by the Purchaser to the Company in regard thereto; provided, however, that (a) Company and its representatives are permitted to inspect and work upon the system involved during reasonable hours, and (b) the Company is notified of the failure within one (1) year after date of shipment of the system so involved.

The warranties hereunder of the Company specifically exclude and do not apply to the following:

a. Products and parts damaged or abused in shipment without fault of the Company.

b. Defects and failures due to operation, either intentional or otherwise, (1) above or beyond rated capacities, (2) in connection with equipment not recommended by the Company, or (3) in an otherwise improper manner.

c. Defects and failures due to misapplication, abuse, improper installation or abnormal conditions of temperature, humidity, abrasives, dirt or corrosive matter.

d. Products, parts and systems which have been in any way tampered with or altered by any party other than an authorized Company representative.

e. Products, parts and systems designed by the Purchaser.

f. Any party other than the Purchaser.

The Company makes no other warranties or representation, expressed or implied, of merchantability and of fitness for a particular purpose, in regard to products manufactured, parts repaired and systems engineered by it.

## 5. Terms of payment

Standard terms of payment are net thirty (30) days from date of the Company invoice. For invoice purposed, delivery shall be deemed to be complete at the time the products, parts and systems are shipped from the Company and shall not be conditioned upon the start up thereof. Amounts past due are subject to a service charge of 1.5% per month or fraction thereof.

## 6. Order cancellation

Any cancellation by the Purchaser of any order or contract between the Company and the Purchaser must be made in writing and receive written approval of an authorized Company representative at its office in Heath Springs, S.C. In the event of any cancellation of an order by either party, the Purchaser shall pay to the Company the reasonable costs, expenses, damages and loss of profit of the Company incurred there by, including but not limited to engineering expenses and expenses caused by commitments to the suppliers of the Company's subcontractors, as determined by the Company.

## 7. Changes

The Purchaser may, from time to time, but only with the written consent of an authorized Company representative, make a change in specifications to products, parts or systems covered by a purchase order accepted by the Company. In the event of any such changes, the Company shall be entitled to revise its price and delivery schedule under such order.

## 8. Returned material

If the Purchaser desires to return any product or part, written authorization thereof must first be obtained from the Company which will advise the Purchaser of the credit to be allowed and restocking charges to be paid in regard to such return. No product or part shall be returned to the Company without a "RETURN TAG" attached thereon which has been issued by the Company.

## 9. Packing

Published prices and quotations include the Company's standard packing for domestic shipment. Additional expenses for special packing or overseas shipments shall be paid by the Purchaser. If the Purchaser does not specify packing or accepts parts unpacked, no allowance will be made to the Purchaser in lieu of packing.

## 10. Standard transportation policy

Unless expressly provided in writing to the contrary, products, parts and systems are sold f.o.b. first point of shipment. Partial shipments shall be permitted, and the Company may invoice each shipment separately. Claims for non-delivery of products, parts and systems, and for damages thereto must be filed with the carrier by the Purchaser. The Company's responsibility therefor shall cease when the carrier signs for and accepts the shipment.

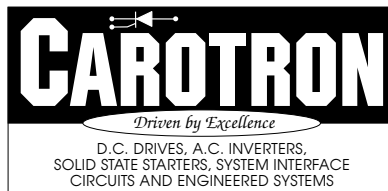

3204 Rocky River Road  
Heath Springs, SC 29058  
Phone: (803) 286-8614  
FAX: (803) 286-6063

**MAN1016-0E**  
**Issued 11-17-11**