

BLAZER

D.C. MOTOR CONTROL

Instruction Manual
BDP 402-XXX
BDP 405-XXX



Table of Contents

1. General Description	2
2. Specifications & technical data	3
2.1 Electrical	3
2.2 Physical	3
3. Installation.....	4
3.1 Circuit Protection	4
3.2 Connection Information	4
4. Programming & adjustments.	7
4.1 Programming Jumpers – Control Board	7
4.2 Programming Jumpers – Power Board	7
4.3 Potentiometers	8
4.4 Adjustment Procedure – Speed Regulator	9
4.5 Adjustment Procedure – Torque Regulator	10
4.6 Adjustment Procedure – Auto Mode	11
4.7 Adjustment Procedure – Torque/Taper	12
5. Run-Brake models	13
6. Spare parts list.	14
7. Prints	15
D10588 – Schematic, Blazer Control Board	15
D10590 – Assembly, Blazer Control Board	16
D10591 – Schematic, 2 HP Blazer Power Board	17
D10593 – Schematic, 2 HP Blazer Power Board	18
D10597 – Assembly, 2HP Blazer Chassis Models	19
C10642 – Wiring Diagram, 2HP Blazer Chassis Models	20
D10640 – Dimension Drawing, 2HP Blazer Chassis Models	21
D10598 – Assembly, 2HP Blazer Enclosed Models with Controls	22
D10641 – Assembly, 2HP Blazer Enclosed Models without controls	23
C10634 – Wiring Diagram, 2HP Blazer Enclosed Models	24
C10637 – Dimension Drawing, 2HP Blazer Enclosed Models	25
D10653 – Connection Diagram, Models BDP402-E00/EB0/000/OB0	26
D10636 – Connection Diagram, Models BDP402-EOC /EBC	27
D10678 – Schematic, 5 HP Blazer Power Board	28
D10680 – Assembly, 5 HP Blazer Power Board	29
D10681 – Assembly, 5 HP Blazer Chassis Models	30
C10682 – Wiring Diagram, 5 HP Blazer Chassis Models	31
D10683 – Dimension Drawing, 5 HP Blazer Chassis Models	32
D10684 – Assembly, 5 HP Blazer Enclosed Models with Controls	33
D10685 – Assembly, 5 HP Blazer Enclosed Models without Controls	34
C10687 – Wiring Diagram, 5 HP Blazer Enclosed Models	35
D10686 – Dimension Drawing, 5 HP Blazer Enclosed Models	36
D10688 – Connection Diagram, Models BDP405-EOO/EBO/OOO/OBO	37
D10689 – Connection Diagram, Models BDP405-EOC/EBC	38

The Carotron Blazer™ BDP40X Series of D.C. motor controls provides a full range of speed or torque control of shunt wound or permanent magnet D.C. motors. Model BDP40X operates motors between 1/4 and 5 horsepower. 12 standard models are offered in compact chassis or enclosed assemblies. Models BDP402 is customer connectable for operation at 115 VAC or 230 VAC single phase input. When operated at 115 VAC input, each unit supplies variable armature voltage up to 90 VDC and a fixed field voltage of 100 VDC. For operation at 230 VAC input, each model supplies up to 180 VDC for armature voltage and a fixed field of 200 VDC. Models BDP405 is customer connectable for operation with 230 VAC single phase input. Each model supplies up to 180 VDC for armature voltage and a fixed field supply of 200 VDC.

Each model is supplied with the following standard features unless otherwise noted.

Features

- AC line contactors for safety disconnect in stopped condition
- AC line fuses for circuit protection
- Control circuit fuses
- Isolation amplifier for providing isolated armature current feedback
- Impedance isolation, 5 Meg Ohms, for armature voltage feedback isolation
- Independently adjustable linear Accel and Decel, 1 to 60 seconds
- Inner current loop for fast stable response
- Hard firing, high frequency multi-pulse gating circuit for reliable SCR firing over a wide range of speed and load characteristics
- Armature current range selectable by jumper, 6 levels
- Tachometer and encoder feedback are insensitive to direction of motor rotation
- Jumper selectable armature voltage, tachometer voltage (7 or 50 VDC/1000RPM), or encoder (60 or 300 PPR) feedback
- Encoder power supply, +12 VDC @ 100 mA, terminal strip accessible
- Digital logic for sequencing Start, Stop and Jog operation for dry circuit switching of line contactors to extend contactor life
- Velocity or torque mode operation selectable
- Built-in Torque/Taper control function with provision for external torque pot
- Jog Delay to allow rapid jogging without de-energizing the line contactor to extend contactor life
- Terminal strip access to Accel/Decel output, Velocity loop output and current loop input for systems interface
- Internal jog pot for adjustment of Jog Speed
- Auto Mode for 4 to 20 mA input for process follower operation
- Summing input with on board trim pot to allow voltage summing with speed reference
- Jumper selection to allow summing input to be clamped or not clamped in the Jog Mode
- De-pluggable terminals for all customer connections except line and armature connections
- Power On/Off switch for control circuit (enclosed models only)
- Solid state dynamic braking (model with D.B. only) for the BDP402 models
- Contactor dynamic braking (models with D.B. only) for the BDP405 models
- Membrane switch control panel for Start, Stop, and Jog pushbuttons (enclosed models with control panel only)

2.1 Electrical

A.C. input

- 115 VAC $\pm 10\%$, 50/60Hz ± 2 Hz - BDP402
- 230 VAC $\pm 10\%$, 50/60 Hz ± 2 Hz

Armature output

- 0 – 90 VDC for 115 VAC input - BDP402
- 0 – 180 VDC for 230 VAC input - BDP402
- 0 – 180 VDC - BDP405

Field output

- 100 VDC @ 1 Amp for 115 VAC input - BDP402
- 200 VDC @ 1 Amp for 230 VAC input - BDP402
- 200 VDC @ 1 Amp BDP405

Horsepower range

- $\frac{1}{4}$ - 1 HP @ 90 VDC – BDP402
- $\frac{1}{2}$ - 2 HP @ 180 VDC – BDP402
- $\frac{1}{2}$ - 5 HP @ 180 VDC – BDP405

Adjustments

- Minimum Speed: 0 to 25% of rated armature voltage
- Maximum Speed: 70 to 110% of rated armature voltage
- Jog Speed: 0 to 25% of rated armature voltage
- Sum Trim: 0 to 150% of Summing Input
- Acceleration: 1 to 60 seconds
- Deceleration: 1 to 60 seconds
- Current Limit: 0 to 150% of current range selected
- IR Compensation: range set by Current Limit jumper
- Taper (Torque/Taper Mode): sets tension level for full package diameter

- Torque (Torque/Taper Mode): sets tension level for core diameter
- Offset (Auto-Mode): nulls auto circuit with minimum process signal input
- Gain (Auto-Mode): sets speed with maximum process signal input

Speed range

- 20:1 Motor Dependent

Speed regulation

- Armature Feedback: $\pm 2.0\%$ of base speed
- Tachometer or Encoder Feedback: $\pm 0.5\%$ of base speed

Torque regulation

- $\pm 2\%$ of current range selected

Cycle rate (brake models)

- 6 Start/Stop cycles per minute maximum – DBP402
-
- 2 Start/Stop cycles per minute maximum (consult factory if more cycles are required) – DBP405

Temperature range

- 0 - 55° C for chassis units
- 0 - 40° C for enclosed units

2.2 Physical

- Refer to prints D10640 and D10637 in SECTION 7 for complete mounting dimension information on all models DBP402
- Refer to prints D10683 and D10686 in Section 7 for complete mounting dimension information on all models DBP405

3.1 Circuit Protection

Wire size and fusing should be based on local electrical codes at each installation. Input requirements with recommended fuse size and type per horsepower are listed in the table below. Models supplied from the factory with line fuses are fused to allow use at the maximum horsepower rating. Wiring should be based on this rating unless the fuse sizes are reduced per the actual horsepower of the motor in use.

HP	Input Voltage	Input A.C. Current @ F. L.	Recommended Fuse
¼	115 VAC	4.3 AMPS	5 AMP, MDA
½	115 VAC	7.9 AMPS	8 AMP, MDA
¾	115 VAC	11.7 AMPS	15 AMP, MDA
1	115 VAC	15.0 AMPS	20 AMP, MDA
½	230 VAC	4.3 AMPS	5 AMP, MDA
1	230 VAC	7.9 AMPS	8 AMP, MDA
1 ½	230 VAC	12.2 AMPS	15 AMP, MDA
2	230 VAC	15.0 AMPS	20 AMP, MDA
3	230 VAC	22.0 AMPS	35 AMP, SC
5	230 VAC	34.0 AMPS	40 AMP, SC

NOTE: Fuses shown are manufactured by Bussmann. Littelfuse type 326 may be substituted.

3.2 Connection Information

Refer to Connection Diagram D10635 for Models BDP402-EOO, EBO, OOO & OBO and D10636 for Models BDP402-EOC & EBC.

Refer to Connection Diagram D10688 for Models BDP405-E00, EB0, 000, OB0 and D10689 for Models BDP405-E0C & EBC.

Wiring Precautions

- **WARNING!!!** Although the BDP405 Control Circuit is isolated, high voltage potentials can be present between earth ground and any point in the circuit

depending on what the control circuit is connected to. All test instruments should be isolated from earth ground to prevent damage to the instrument or control.

- Ground the control only at TB2-11 model DBP402.
- Ground the control only at TB2-7 model DBP405.
- Use shielded cable for all speed pot., tachometer, encoder, start, stop, jog and special signal wiring. These wires should be routed away from all A.C. power, armature, field and relay coil wiring. Connect the shield to circuit common at the control end only. The shield should not be connected to earth ground at either end. Connecting the shield to earth ground may result in noise problems.
- Any relays, contactors, motor starters, solenoids, etc. located in close proximity to or on the same A.C. line as the BDP40X control should have a transient suppression device in parallel with the coil to minimize interference with the control.

Terminal connections

- **TB1 – 1, 2 & 3 (Speed Pot):**
A potentiometer with a resistance value between 2,000 Ohms and 10,000 Ohms connects to these terminals. The CCW lead and shield connect terminal 1. The wiper connects to terminal 2 and the CW lead connects to terminal 3.
- **TB1 – 4 (Torque):**
A reference voltage (0 – 10VDC) applied to this terminal will set the tension at core when Torque Taper mode is desired.
- **TB1 – 5 & 6 (Stop):**
Monetarily closing a set of contacts across these terminals will stop the drive.

- **TB1 – 6 & 7 (Start):**
Monetarily closing a set of contacts across these terminals will start the drive and allows the output to accelerate to a level set by the speed pot.
- **TB1 – 8 & 9 (Jog):**
Closing a set of contacts across these terminals allows the output to accelerate to a level set by the Jog Speed Pot.
NOTE: Jog will only operate after the drive is stopped.
- **TB1 – 10 & 11 (Auto):**
Closing a set of contacts across these terminals will allow the drive to accept a 4 – 20mA input at TB1 – 14 & 15 as a speed reference. All other reference commands will be ignored except for the Minimum Speed Potentiometer.
- **TB1 – 12 & 13 (Summing Input):**
This terminal is summed directly with reference signals applied to TB1 – 2. Input signals should not exceed $\pm 10\text{VDC}$ and should be disabled by disconnecting the signal from TB1 – 12. The effect of the reference applied to the Summing input can be modified by the Sum Trim Potentiometer. Like polarity signals at polarity signals will subtract or offset or each other.
NOTE: A jumper selection is available to allow the Summing input to be clamped or not clamped in the jog mode.
- **TB1 – 14 & 15 (4 – 20 mA Auto Input):**
These input terminals will accept a 4 – 20 mA input when Auto Mode is selected by closing a set of contacts between TB1 – 10 & 11. These terminals provide 270 Ohms of input impedance. Onboard Offset and Gain Potentiometers are available to modify the input signal.
- **TB1 – 16 (Ref. Output):**
This terminal connects directly to the output of the ACCEL/DECEL and jog reference circuit. If the drive is to be used as torque regulator, jumper TB1 – 16 to TB1 – 17. This terminal may also be used as a reference output signal for special engineered applications.

- **TB1 – 17 (Current Loop Input):**
This terminal connects directly to the input of the current integrator. If the drive is to be used as a speed regulator, jumper TB1 – 17 to TB1 – 18. If the drive is to be used as a torque regulator, jumper TB1 – 16 to TB1 – 17. An external torque reference may also be applied to this terminal for special engineered applications. The signal applied must not exceed $\pm 10\text{VDC}$.
NOTE: Although the BDP40X has an isolated control circuit, some signals to and from the drive may require further isolation depending on where the signals originate.
- **TB1 – 18 (Velocity Loop Output):**
This terminal connects directly to the output of the velocity loop integrator. If the drive is to be used as a speed regulator, jumper TB1 – 17 to TB1 – 18.

BDP402

- **TB2 – 1 & 2 (AC Input):**
These terminals are used for the A.C. line input. Either 115 VAC or 230 VAC input can be connected to these terminals. If 115 VAC is to be used as input, place J3, J4 & J6 in the 115 V position. If 230 VAC is to be used as input, place J3, J4 & J6 in the 230 V position.
- **TB2 – 3 & 4 (Armature):**
Motor lead A1 connects to terminal 3 and motor lead A2 connects to terminal 4. These connections will produce CCW motor rotation when viewed from the commutator end. The armature leads should be switched if reverse rotation is desired.
- **TB2 – 5 & 6 (Field):**
Motor field lead F1 connects to terminal 5 and motor field F2 connects to terminal 6. There is no connection required to these terminals when a permanent magnet type motor is used.

- **TB2 – 7 & 8 (Tachometer Input):**
An optional motor mounted 7V or 50V/1000 *RPM* tachometer may be connected to these terminals for speed feedback with 1750 *RPM* base speed motors. See connection diagrams in SECTION 8 for proper connection.
- **TB2 – 8, 9 & 10 (Encoder Input):**
An optional motor mounted 60 or 300 *PPR* encoder may be connected to these terminals. See connection diagrams in SECTION 8 for proper connection.
- **TB3 – 1 & 2 (DB 115V Only):**
These terminals are used to select how many braking resistors are used in the circuit. TB3 – 1 should be jumpered to TB3 – 2 only if 115 VAC is being used as input. For 320 VAC input no jumper should be added between these terminals.

BDP405

- **L1 & L2 (AC Input):**
These terminals are used for the 230 VAC line input.
- **A1 & A2 (Armature):**
Motor lead A1 connects to terminal 3 and motor lead A2 connects to terminal 4. These connections will produce CCW motor rotation when viewed from the commutator end. The armature leads should be switched if reverse rotation is desired.

- **TB1 & 2 (Field):**
Motor field lead F1 connects to terminal 1 and motor field F2 connects to terminal 2. There is no connection required to these terminals when a permanent magnet type motor is used.
- **TB2 – 3 & 4 (Tachometer Input):**
An optional motor mounted 7V or 50V/1000 *RPM* tachometer may be connected to these terminals for speed feedback with 1750 *RPM* base speed motors. See connection diagrams in Section 7 for proper connection.
- **TB2 – 4, 5 & 6 (Encoder Input):**
An optional motor mounted 60 or 300 *PPR* encoder may be connected to these terminals. See connection diagrams in Section 8 for proper connection.
- **TB2 – 7 (Ground):**
Only this terminal should be connected to earth ground.

4.1 Programming Jumpers: Control Board

J1 (Summing Clamp):

The selection of CLP will allow a reference applied to the Summing input to be clamped when jogging. If CLP is selected, the reference applied to the Summing input will not be clamped when jogging.

J2 (Feedback):

Velocity (speed) feedback can come from either of several sources.

- When using armature voltage feedback, place J2 in the AFB position.
- Select EFB if an encoder is being used for feedback.
- Select tachometer feedback by placing J2 in the TFB position.

4.2 Programming Jumpers: Power Board

BDP402

J3 & J4 (A.C. Input Voltage)

- The J3 & J4 jumper wires program the power supply transformer according to the A.C. line voltage to be used. Position each at 115V for 115 VAC input for 230 VAC input.

**TABLE 2
JUMPER POSITION
BDP 402**

Input Voltage	Jumper Position			
	3 AMP	6 AMP	8 AMP	11 AMP
115 VAC	¼ HP	½ HP	¾ HP	1 HP
230 VAC	½ HP	1 HP	1 ½ HP	2 HP

J5 (Armature Current/Torque Range)

Four full load current ranges are selectable for different motor ratings. The Current Limit pot. has a range equal to 150% of the value selected. Refer to TABLE 2 to select the power jumper location based on motor horsepower and input voltage.

J6 (A.C. Input Voltage)

J6 selects the armature feedback voltage level according to the A.C. line voltage to be used. Position at 115V for 115 VAC input or 230V for 230 VAC input.

J7 (Encoder Feedback)

When operating in tachometer feedback, use J7 to select for 60 or 300 *PPR* according to the rating of the encoder used.

J8 (Tach Feedback)

When operating in tachometer feedback, use J8 to select for 7V or 50V per thousand *RPM* according to the rating of the tachometer.

BDP405

J3 (Encoder Feedback):

When operating in encoder feedback, use J3 to select for 60 or 300 *PPR* according to the rating of the encoder used.

J4 (Tach Feedback):

When operating in tachometer feedback, use J4 to select for 7V or 50V per thousand *RPM* according to the rating of the tachometer.

**TABLE 2 (cont.)
JUMPER POSITION
BDP405**

Input Voltage	3 AMP	6 AMP	8 AMP	11 AMP	15 AMP	25 AMP
230 VAC	½ HP	1 HP	1 ½ HP	2 HP	3 HP	5 HP

J5 (Armature Current/Torque Range):

Six full load current ranges are selectable for different motor ratings. The Current Limit pot. has a range equal to 150% of the value selected. Refer to the table below to select the proper jumper location based on motor horsepower and input voltage.

4.3 Potentiometers: Control Board

Sum Trim P1

The Sum Trim control the percentage affect of a signal applied to TB1 – 12, Summing input. It can trim this signal to 0 or increase the signal to approximately 150%.

Jog Speed P2

Jog Speed controls output only when in the Jog mode and can produce up to 25% output. Like the Max Speed, its signal is summed with the Min Speed pot signal and the Summing Input signal when CLP is selected at J1.

Cur Limit P3 (Current Limit):

Current Limit sets the maximum armature current level. Its range is 0 to 150% of the current value selected by jumper J5. Clockwise rotation increases the current limit setting. When the control is operated as a torque regulator, the C. Limit pot. should be turned full CW since the range of current is set by other adjustments.

IR Comp P4 (IR Compensation):

The IR Comp pot is functional only when operating in the AFB, armature feedback mode. It is used to improve motor speed regulation by using some of the current amplifier output as a positive feedback signal summed with the speed reference signal. Its effect is to keep motor speed from dropping as load is increased. This drop in speed is due to IR losses in the motor. Individual motors have different IR losses and those losses have greater effect in the lower half of the speed

range. For these reasons, P12 is best adjusted with the actual load motor to be used, under normal loading conditions for the application and at the speed normally run.

Min Speed P5

The Minimum Speed sets the minimum armature output voltage when all other inputs are at zero. It can set up to 25% output voltage. Its signal adds to and sets the starting point for other reference signals including the 4 – 20 mA reference when Auto Mode is used.

Taper P6

The Taper Potentiometer is used to set the tension at full roll diameter when Torque/Taper Mode is used.

Max Speed P7

Maximum Speed trims the output of the Accel/Decel circuit and sets the maximum effect of the reference signal applied to TB1 – 2 by the external speed pot. P7 ranges the output from 70 to 110% when P5 is set properly.

Torque P8

P8 is used to set the tension of a roll at core when torque/Taper Mode is used. If an external Torque Potentiometer is used, turn P8 full counter clockwise.

Accel P9

The Acceleration pot controls the time for the motor to accelerate along a linear ramp to the set speed. It can set the time from 1 to 60 seconds. CW (clockwise) rotation increases the time. The time period can be related approximately to the physical setting of the pot.

Example: Starting at minimum, full CCW, and rotating the pot 50% to mid-position would give an approximate accel time of 30 seconds.

Gain P10 (Auto Mode ONLY):

Used to set the maximum output level with maximum reference input.

Decel P11

The Deceleration pot controls the time for the motor to decelerate along a linear ramp to the set speed. Like the ACCEL pot, its 60 second setting is at full CW rotation.

NOTE: The Blazer™ drive can control decel time only when the normal inherent decel time (coast down time) is equal to or shorter than the desired decel time.

Offset P12 (Auto Mode):

Used to null the auto mode amplifier to 0.0VDC with minimum reference input.

4.4 Adjustment Procedure: Speed Regulator

Step 1

BDP402

- Visually inspect all connections to check for tightness, proper insulation and agreement with the connection diagram. ONLY TB2 – 11 should be connected to earth ground.
- Verify the line voltage level and the jumper locations of J3, J4, & J6.

BDP405

- Visually inspect all connections to check for tightness, proper insulation and agreement with the connection diagram. ONLY TB2 – 7 should be connected to earth ground.
- Verify 230 VAC line voltage.

BDP40X

- Note the motor nameplate full load current and select the proper current range at J5. Place jumper J2 in the AFB position even if tachometer or encoder feedback is to be used.

- Install a jumper between TB1 – 17 & TB1 – 18.
- Initially set the potentiometers as follows:

MIN SPEED – P5.....full CCW
MAX SPEED – P7.....mid-range
IR COMP – P4.....full CCW
CUR. LIMIT – P3.....full CW
ACCEL – P9.....mid-range
DECEL – P11.....mid-range
SUM TRIM – P1.....full CCW
TORQUE – P8.....full CW
TAPER – P6.....full CCW
GAIN – P10.....full CCW
OFFSET – P12.....full CCW
JOG SPEED – P2.....mid-range

- If a tachometer or encoder is used with the control, verify that (J7 or J8) for the BDP402, or (J3 or J4) for the BDP405 agrees with the tachometer or encoder rating.

Step 2

- With no load on the motor or machine and with the speed potentiometer at zero, apply power to the control. Monetarily close a set of contacts across TB1 – 6 & 7 to start the drive. Models BDP40X-E0C & BDP40X-EBC only require pressing the Start button.
- Increase the MIN SPEED pot CW until the motor just begins to creep and then CCW until the motor just stops.

Step 3

Rotate the speed pot to maximum. Measure the motor speed or armature voltage. Adjust the MAX SPEED pot for base speed or full rated armature voltage.

Step 4

(Armature feedback only – Omit this step if tachometer feedback is used.)

- Adjust the speed pot to mid-range or if known the speed at which the motor will be run most often. Closely note the motor or line speed. Apply rated or normal machine

load to the motor. The speed will usually drop off a small percentage. Increase the IR pot clockwise until the loaded speed matches the unloaded speed. Recheck the unloaded speed level and repeat this step until there is no difference in the speed from no load to full load.

NOTE: The signal from the IR pot may affect the MIN SPEED and MAX SPEED pot settings. Recheck MIN SPEED and MAX SPEED after adjusting the IR pot and readjust if necessary.

Step 5 (Tachometer Feedback Only):

- With the control in armature feedback, run the motor at full speed and verify approximately 5V at TP9 on the control board.
- Remove power from the control. Move J2 from AFB position to the TFB position.
NOTE: The settings of the MIN & MAX SPEED potentiometers may vary due to variations in tachometer voltage. Repeat step 2 & 3 if necessary.

Step 6 (Encoder Feedback Only):

- With the control in armature feedback, run the motor at full speed and verify approximately 5V at TP10 on the control board.
- Remove power from the control. Move J2 from AFB position to the EFB position.
NOTE: The settings of the MIN & MAX SPEED potentiometers will need to be checked. Repeat steps 2 & 3 if necessary.

Step 7

- The CURRENT LIMIT pot is factory adjusted for 150% of current range selected at J5 when the motor is stalled.
NOTE: The motor armature should never be energized at stall for more than a few seconds to prevent the chance of overheating the windings and degrading the insulation.

- Should it become necessary to readjust the CURRENT LIMIT pot, use the following procedure:

- a. Insert a D.C. ammeter in series with the motor armature or use a true RMS D.C. clamp on meter. A.C. clamp-on meters are not recommended since they will not give an accurate indication of armature current.
- b. Mechanically lock the motor shaft to prevent it from turning.
- c. Set the CURRENT LIMIT pot to 25% CW.
- d. Set the Speed pot to 50% CW
- e. Select the proper current range with jumper J5.
- f. Apply power and start the control, also increase the CURRENT LIMIT pot to allow 150% of motor nameplate full load current.
- g. Remove the power and the mechanical lock on the motor shaft.

Step 8

Adjust the ACCEL and DECEL pots as required to achieve the desired rate of speed change. Clockwise rotation increases time.

4.5 Adjustment Procedure: Torque Regulator

Step 1

- Visually inspect all connections to check for tightness, proper insulation and agreement with the connection diagram. ONLY TB2 – 7 should be connected to earth ground.
- Verify the line voltage level and the jumper locations of J3, J4 & J6. (Models BDP402)
- Verify 230 VAC line voltage. (Models BDP405)
- Note the motor nameplate full load current and select the proper current range at J5

- Remove jumper between TB1 – 17 & TB1 – 18. Install a jumper between TB1 – 16 & TB1 – 17.
- Initially set the potentiometer as follows:

MIN SPEED – P5.....full CCW
MAX SPEED – P7.....mid-range
IR COMP – P4.....full CCW
CUR. LIMIT – P3.....full CW
ACCEL – P9.....mid-range
DECEL – P11.....mid-range
SUM TRIM – P1.....full CCW
TORQUE – P8.....full CW
TAPER – P6.....full CCW
GAIN – P10.....full CCW
OFFSET – P12.....full CCW
JOG SPEED – P2.....full CCW

NOTE: In the following steps, motor torque should be monitored directly by the use of a D.C. ammeter in series with the armature. Full rated torque is produced at full rated current. The motor shaft must be mechanically locked to prevent rotation.

Step 2

In the torque regulator mode, the external pot. connected to TB1 – 1, TB1 – 2, and TB1 – 3 becomes the torque reference pot. Turn this pot full CCW. Apply power to the control and momentarily close a set of contacts across TB1 – 6 & 7 to start the drive. Model BDP40X-E0C & Model BDP40X-EBC only require pressing the Start button.

Step 3

Turn the Torque Reference Potentiometer to 100%. Adjust the CURRENT LIMIT potentiometer for 100% motor rated current output.

NOTE: Do not operate the motor for more than several seconds at full load while stalled to prevent overheating.

Step 4

Adjust the ACCEL and DECEL pots to control the desired rate of change in response to a change in the torque reference pot. Clockwise adjustment of the ACCEL and DECEL pots increases time.

Step 5

Turn off the power and remove the mechanical lock from the motor shaft. The torque regulator is now ready for use. Use caution in operating the motor at slow speeds near rated torque to prevent overheating. Check the speed range of the motor to determine the lowest continuous operating speed at full torque.

4.6 Adjustment Procedure: Auto Mode

Step 1

Complete adjustment procedure in Section 4.5 before proceeding the following step.

Step 2

- Connect the current input per connection diagrams in Section 7.
- Close a set of contacts across TB1 – 10 & 11.
- With no load on the motor or machine and with the current input at a zero, apply power to the control.
- Apply the minimum current reference input. Turn the GAIN potentiometer full clockwise (approximately 20 turns.) Adjust the OFFSET potentiometer for 0.0VDC at TB17. Turn the GAIN potentiometer full counter clockwise.
- Adjust the MIN SPEED potentiometer for the minimum desired speed, with the minimum current reference input.
- Apply the maximum current reference and adjust the GAIN potentiometer for maximum desired speed with maximum current reference input.

NOTE: ACCEL & DECEL Functions are controlled by the rate of change in the current-input signal.

4.7 Adjustment Procedure: Torque/Taper Mode

Step 1

- Refer to connection diagram D10688 for Models BDP405-E00, EB0, 000 & 0B0 and D10689 for Models BDP405-E0C & EBC.
- Visually inspect all connections to check for tightness, proper insulation and agreement with the connection diagram. ONLY TB2 – 7 should be connected to earth ground.
- Verify 230 VAC line voltage.
- Note the motor nameplate full load current and select the proper current range at J5.
- Place jumper J2 in the AFB position.
- Place a jumper between TB1 – 2 & 3.
- Initially set the potentiometer as follows:

MIN SPEED – P5.....full CCW
MAX SPEED – P7.....mid-range
IR COMP – P4.....full CCW
CUR. LIMIT – P3.....full CW
ACCEL – P9.....mid-range
DECEL – P11.....mid-range
SUM TRIM – P1.....full CCW
TORQUE – P8.....full CW
TAPER – P6.....full CCW
GAIN – P10.....full CCW
OFFSET – P12.....full CCW
JOG SPEED – P2.....full CCW

Step 2

If an External Torque Potentiometer is used, turn the P.C. mounted TORQUE

potentiometer full counter clockwise. Connect the potentiometer to TB1 with the wiper on TB1 – 4, the CW lead on TB1 – 3, and the CCW lead on TB1 – 1.

Step 3

Turn the Torque Potentiometer full clockwise. Leave the Current Limit Potentiometer as set from the factory (approximately 75% clockwise.)

Step 4

With no load on the motor, apply power to the drive. Momentarily close a set of contacts between TB1 – 6 & 7 to start the drive. Models BDP40X-E0C & BDP40X-EBC only require pressing the Start button. Adjust the no load speed (core speed) using the MAX Potentiometer on the control board. Use the ACCEL Potentiometer to adjust the acceleration time on start-up.

Step 5

Adjust the Torque Potentiometer counter clockwise to set the tension at core (counter clockwise decreases tension). The Torque Limit light turns on when the drive begins to limit the output current. Adjust the TAPER Potentiometer clockwise to set the tension at full roll diameter (clockwise increases torque).

Step 6

Adjust the Taper Potentiometer clockwise to set the tension at full roll diameter (clockwise increases tension).

BDP402

- Models BDP402-OBO, BDP402-EBO & BDP402-EBC are designed for Run Brake operation on ¼ to 1 HP, 90VDC armature motors or ½ to 2 HP, 180VDC armature motors.
- 180VDC Application
Insure that nothing is connected to TB3-1 & 2.

WARNING!!! Connections to TB3-1 & 2 may cause damage to the control.

- 90VDC Application
A jumper should be connected from TB3-1 to TB3-2 for dynamic braking. If less dynamic braking is desired, the drive may be operated with the jumper removed from TB3-1 & 2.

BDP405

- Models DBP405-OB0, BDP405-EBC & BDP405-EBC are designed for Run Brake operation on ½ to 5 HP, 180VDC armature motors. Refer to connection diagrams D10688 & D10689 in Section 7 for connection to these models.

BDP402

<u>Parts</u>	<u>Descriptions</u>
D10593-000	Power Board Assembly with Dynamic Brake
D10593-001	Power Board Assembly without Dynamic Brake
D10590-000	Control Board Assembly
FUS1005-05	Line Fuse, 20AMP, 250VAC
PMD1001-00	Power Module, 25AMP, 600V
RES62-0004	Dynamic Brake Resistor, 4 Ohm, 100 Watts
SW15000-00	Control panel (membrane switch)

BDP405

<u>Parts</u>	<u>Descriptions</u>
D10680-000	Power Board Assembly
D10590-000	Control Board Assembly
FUS1002-02	Line Fuse, 40 AMP, 250 VAC
FUS1005-01	Control fuse, 5 AMP, 250 VAC
PMD1002-00	Power Module, 80 AMP, 600V
RES62-0004	Dynamic Brake Resistor, 4 Ohm, 100 Watts
SW15000-01	Control panel (membrane switch)
REL2000-02	AC Contactor, 40 AMP, 3 pole
REL2000-03	AC Contactor, 40 AMP, 2 pole

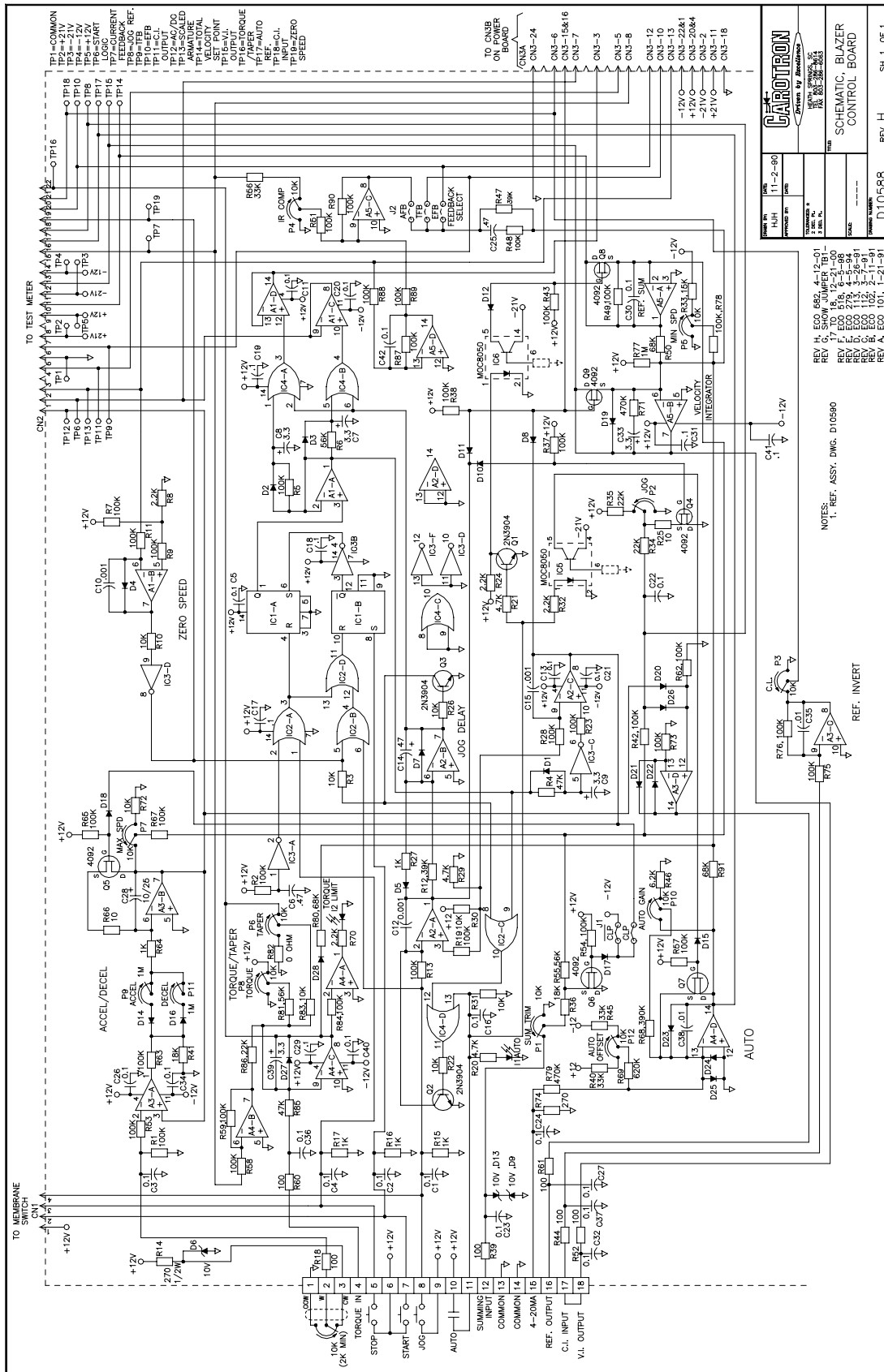

REV. H	11-2-90
DESIGNED BY	...
DRAWN BY	...
CHECKED BY	...
APPROVED BY	...
DATE	...
CAROTRON MEMPHIS, TENNESSEE A DIVISION OF AUTODRIVE	
SCHEMATIC, BLAZER CONTROL BOARD	
D10588	REV. H SH. 1 OF 1

REV. H. ECO. 82, 4-12-91
 REV. G. SHOW JUMPER 'B' -
 REV. F. ECO. 78, 2-5-90
 REV. E. ECO. 78, 4-5-90
 REV. D. ECO. 78, 3-7-91
 REV. C. ECO. 112, 3-7-91
 REV. B. ECO. 107, 2-1-91
 REV. A. ECO. 107, 2-1-91

NOTES:
 1. REF. ASSY. DWG. D10580

REF. INVERT

TO MEMBRANE

TO TESTER

TO CN5B ON POWER BRD

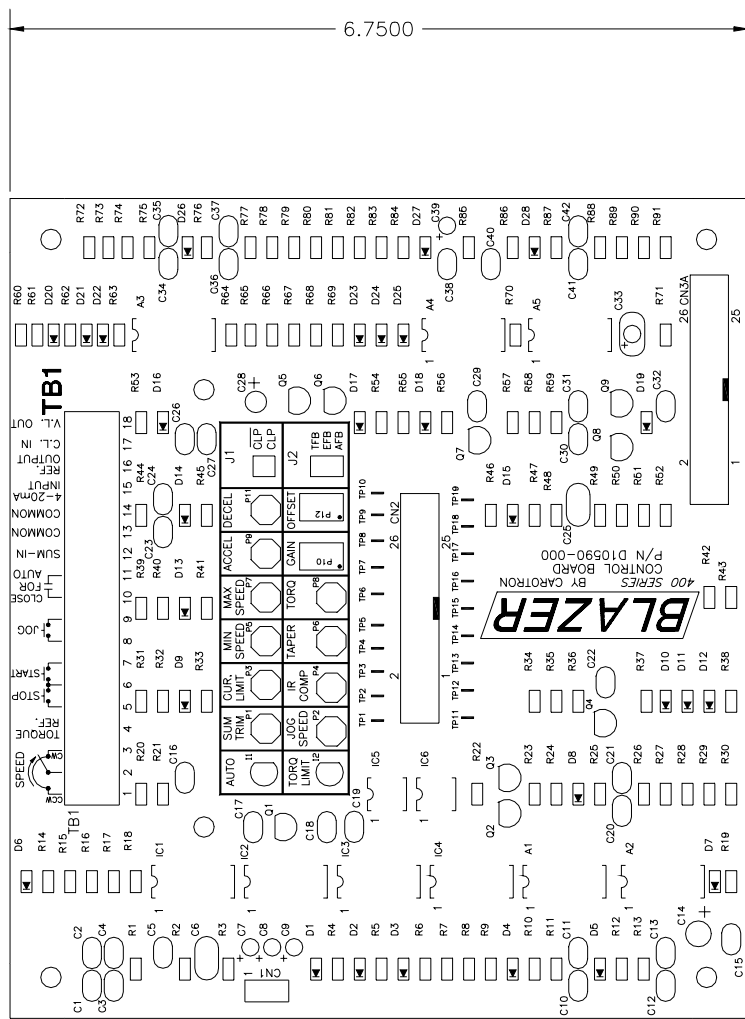

NOTES:
 1. REF. SCHEM. DWG. D10588
 2. REF. B.O.M. A10590

REV. A. ECO 102, 2-13-91

DATE	2-12-91
DESIGNED BY	WRM
DATE	
APPROVED BY	
DATE	
 <small>System by Revolution</small>	
<small>TEL: 800-261-1813</small> <small>FAX: 800-261-8063</small>	
PART NO.	D10590-000
DESCRIPTION	ASSY., BLAZER CONTROL BOARD
REV. A	REV. A
D10590	
SH. 1 OF 1	

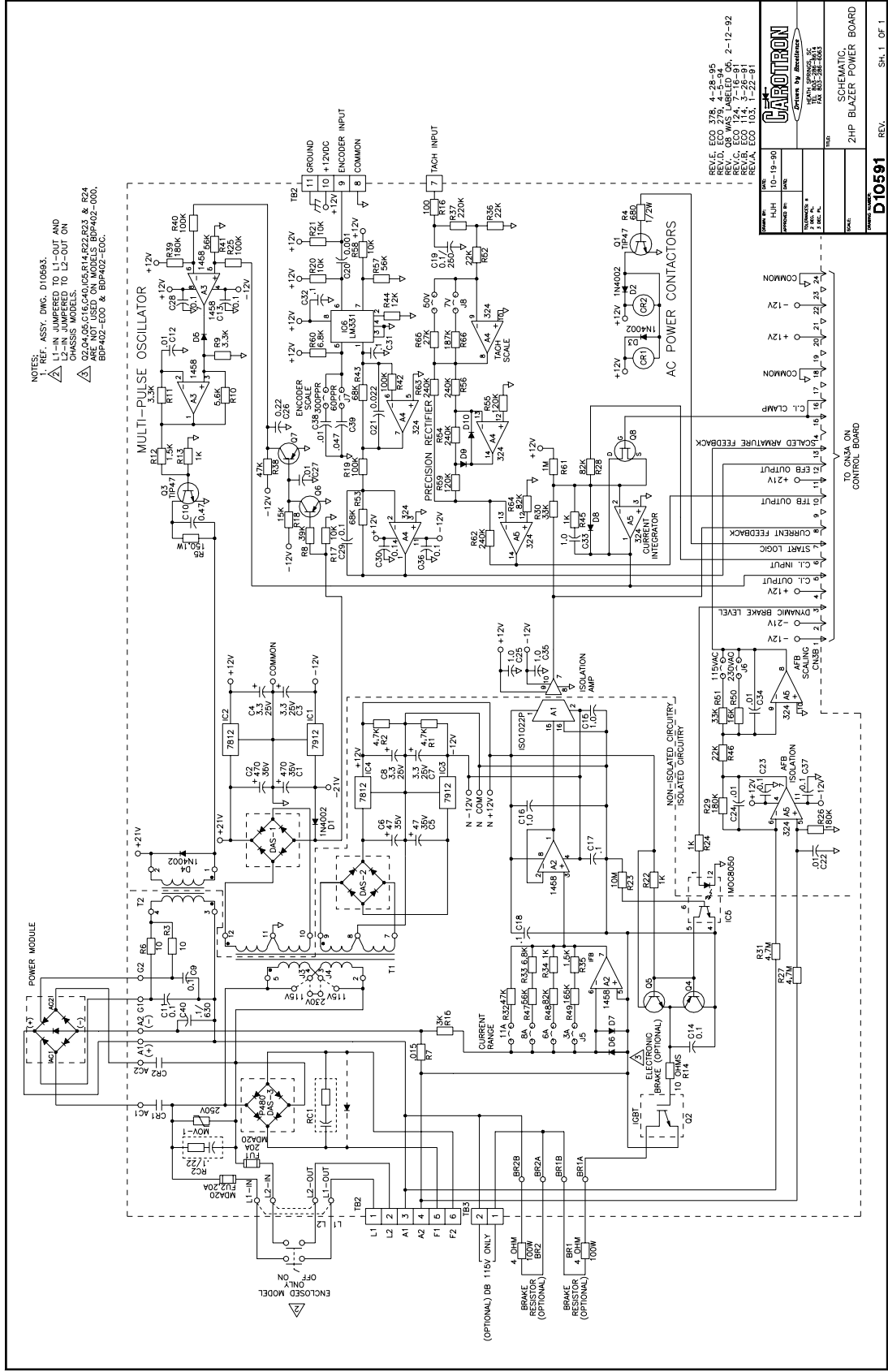

PARATRON
 DIVISION OF INTERNATIONAL
 ELECTRONIC CORP.
 10000 WILSON BLVD.
 WILSON, CA 94093
 (415) 947-2000

DATE: 10-19-90
 DRAWN BY: []
 CHECKED BY: []
 APPROVED BY: []
 TITLE: []

REV. ECO 378, 4-28-95
 REV. L103 WAS LABELLED OK, 2-12-92
 REV. ECO 174, 7-16-81
 REV. ECO 103, 1-22-81

FIG. NO. D10591
 SHEET NO. SH. 1 OF 1

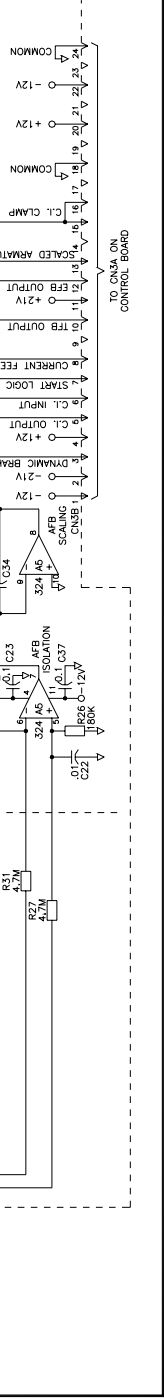

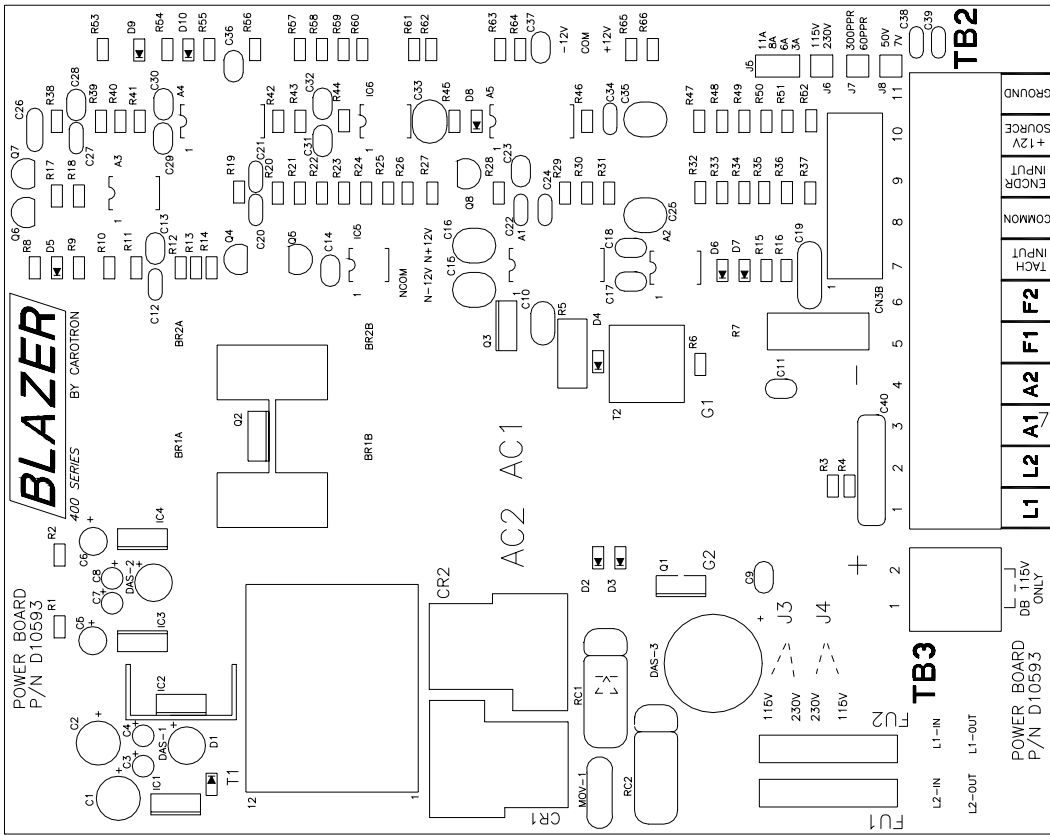

NOTES:
 1. SEE SCHEM. P/N: D10591
 2. REF. B.O.M. A10592
 3. Q2, Q4, Q5, C1, C40, C5, R14, R22, R23, R24
 ARE NOT USED ON MODELS BDP-402-000,
 BDP-402-EG0 & BDP-402-EGC.

DATE	2-6-91
REVISED BY	DATE
 (Part of the Evolution)	
MFG ASSEMBLY, BLAZER POWER BOARD	
SCALE	Z = 1"
REV. C D10593	

REV. C ECO 115, 9-97-91
 REV. B, ECO 104, 2-4-91

MODEL FEATURES	
MODEL NO.	ELECTRONIC BRAKE
BDP402-000	
BDP402-0B0	X

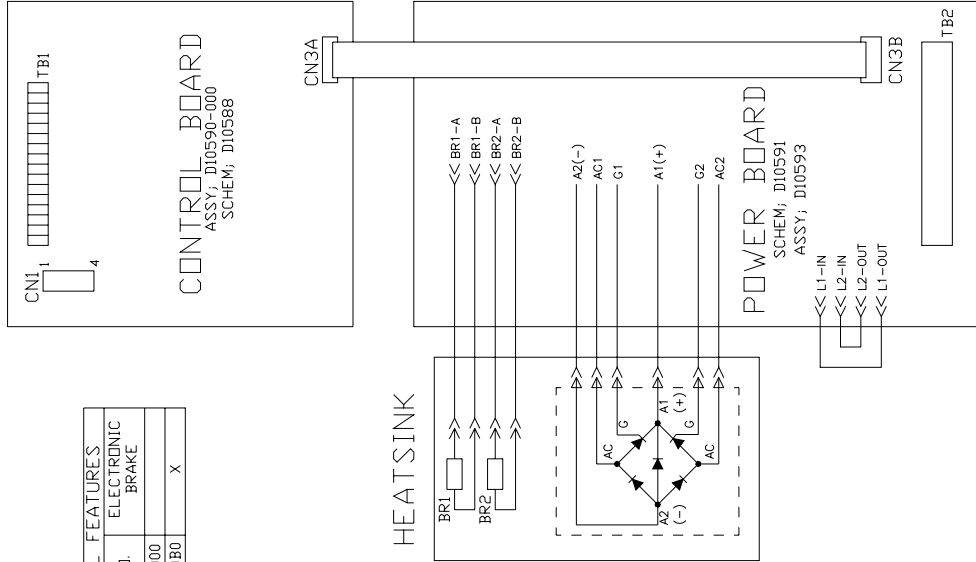

DRAWN BY: HJH	DATE: 1-21-91
APPROVED BY:	DATE:
TOLERANCES: 2 DEC. PL. 3 DEC. PL.	HEATRONICS, INC. HEATRONICS ST. P.O. BOX 286 FAV, TX 75751-0286
SCALE: ---	TITLE: WIRING DIAGRAM, 2HP BLAZER CHASSIS MODELS
DRAWING NUMBER: C10642	REV. SHI OFI

DATE	1-18-91
DESIGNER	HJH
CHECKED BY	
APPROVED BY	
TOLERANCE	± 0.005 IN. ± 0.0005 IN.
SCALE	1:1
 Patterns by Associates	
DIMENSION DRAWING CHASSIS MODELS	
DRAWING NO. D10640 REV. SH. 1 OF 1	

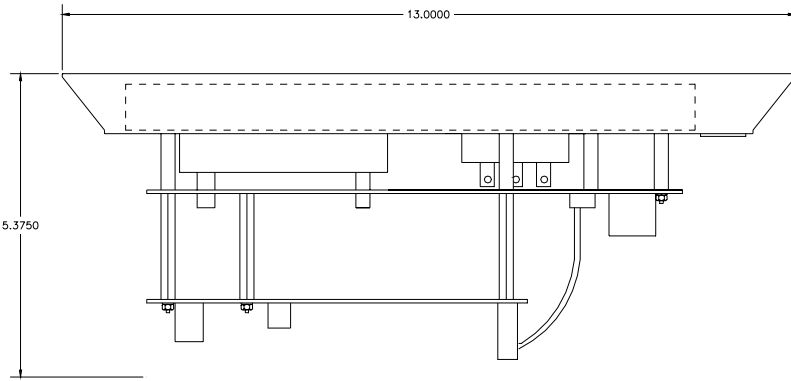
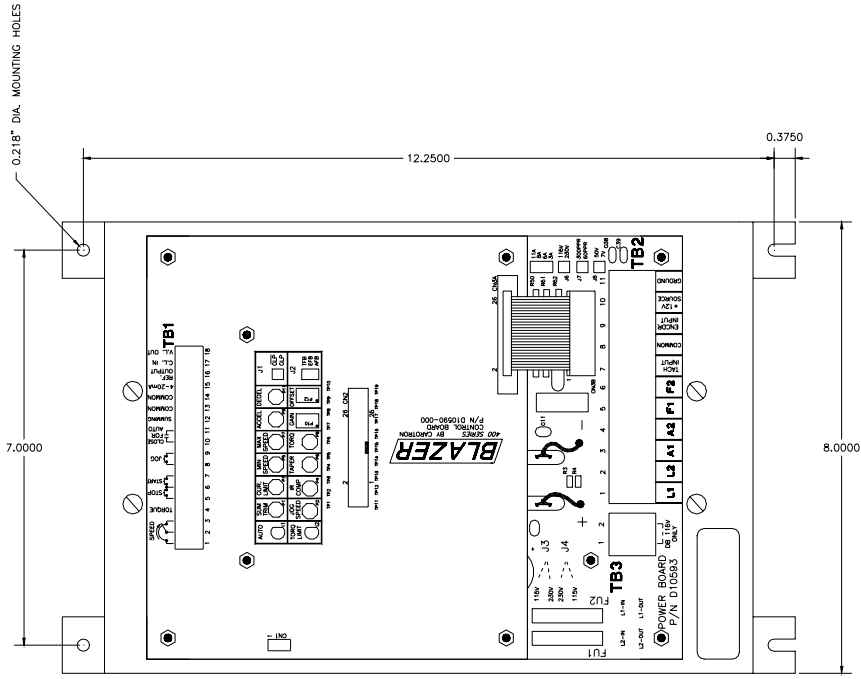

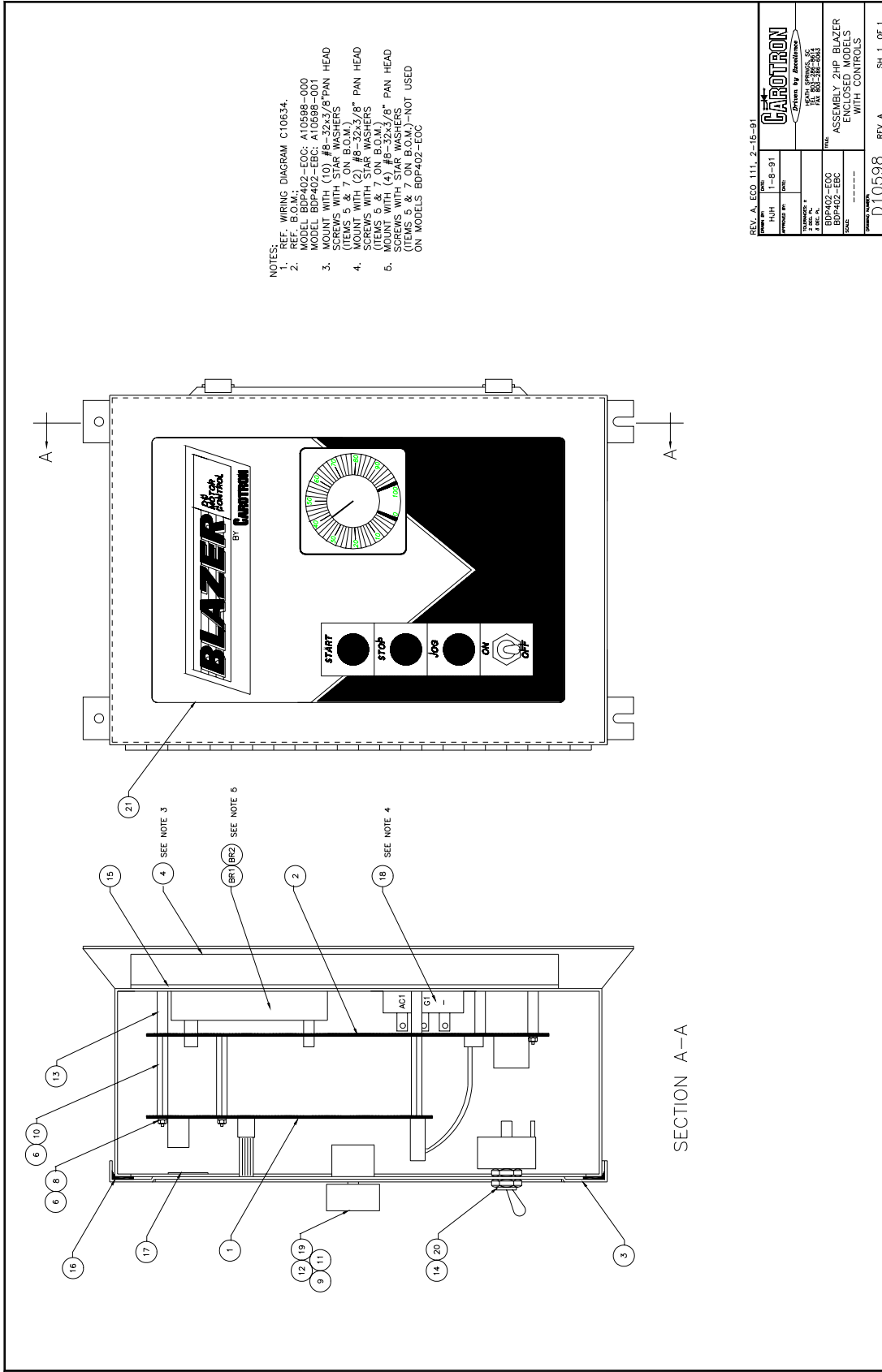

- NOTES:
1. WIRING DIAGRAM C10634.
 2. REF. B.O.M. MODEL BDP402-ECC: A10598-000 MODEL BDP402-EBC: A10598-001
 3. MOUNT WITH (10) #8-32x3/8" PAN HEAD SCREWS WITH STAR WASHERS (ITEMS 6 & 7 ON B.O.M.)
 4. MOUNT WITH (2) #8-32x3/8" PAN HEAD SCREWS WITH STAR WASHERS (ITEMS 6 & 7 ON B.O.M.)
 5. MOUNT WITH (2) #8-32x3/8" PAN HEAD SCREWS WITH STAR WASHERS (ITEMS 5 & 7 ON B.O.M.)—NOT USED ON MODELS BDP402-ECC

REV. A	ECC 111, 2-16-91
H/HT	1-8-91
APPROVED BY	DATE
DESIGNED BY	DATE
CAROTRON Driven by Excellence	
10000 10000 10000 10000 10000 10000	
ITEM	ASSEMBLY 2HP BLAZER ENCLOSED MODELS WITH CONTROLS
QUANTITY	
DESCRIPTION	
DATE	
REV. A	D10598
REV. A	SH. 1 OF 1

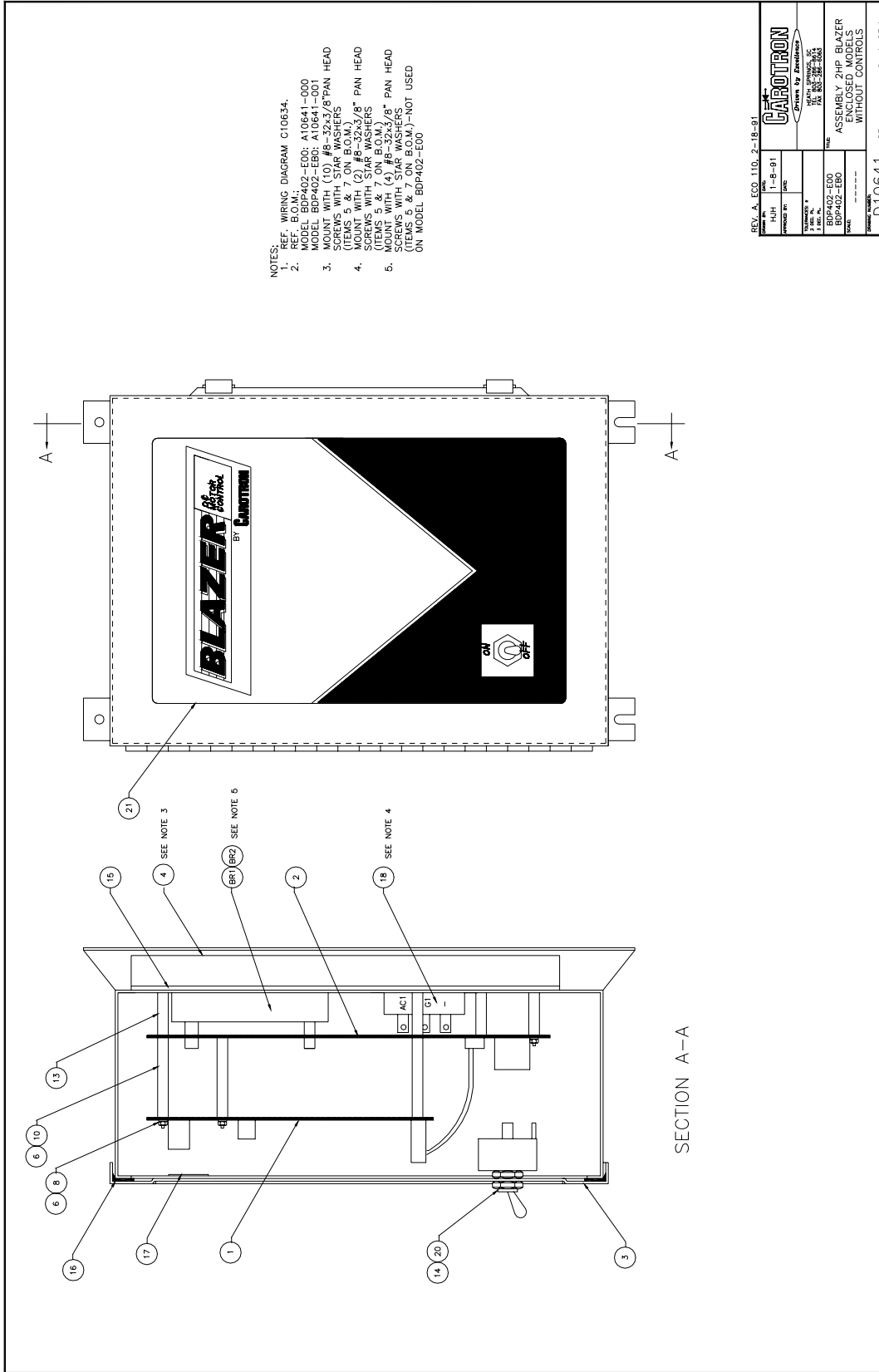

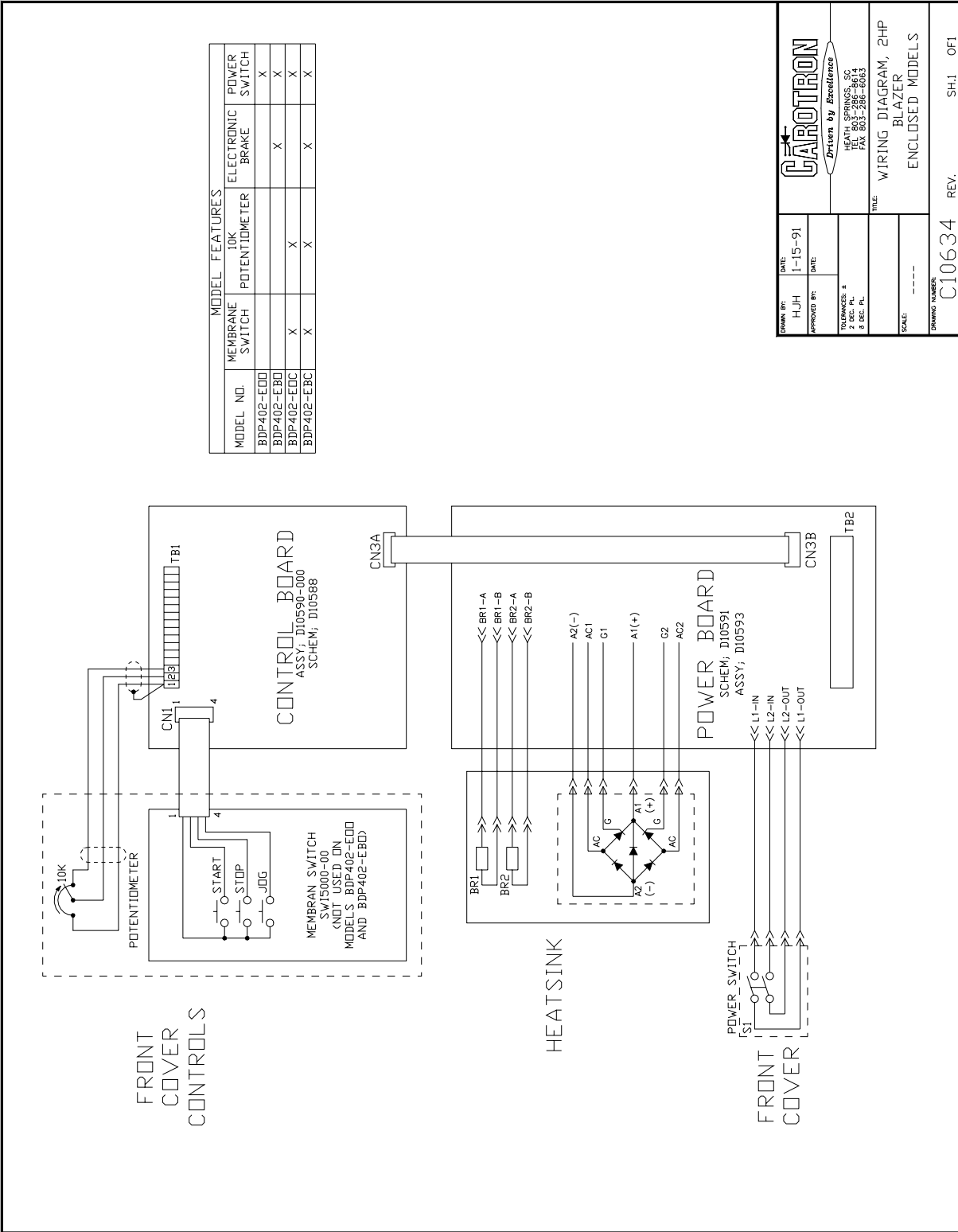

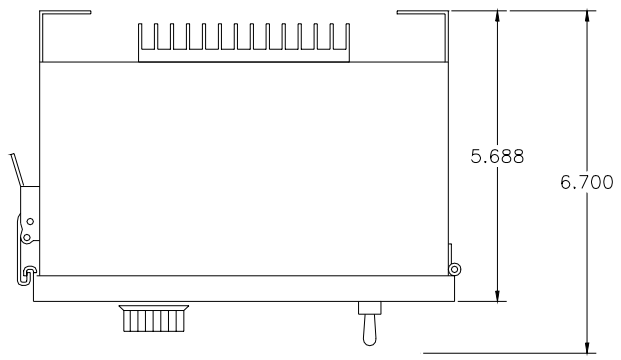

DATE	REV. 1		2000 2001 2002 2003 2004 2005 2006 2007 2008 2009 2010 2011 2012 2013 2014 2015 2016 2017 2018 2019 2020 2021 2022 2023 2024 2025
DESIGNER	DATE		
PROJECT NO.		PROJECT NAME	
SCALE		TITLE	DIMENSION DRAWING 2HP BLAZER ENCLOSED MODELS
DATE		REVISION NUMBER	D 10637
		REV.	SH. 1 OF 1

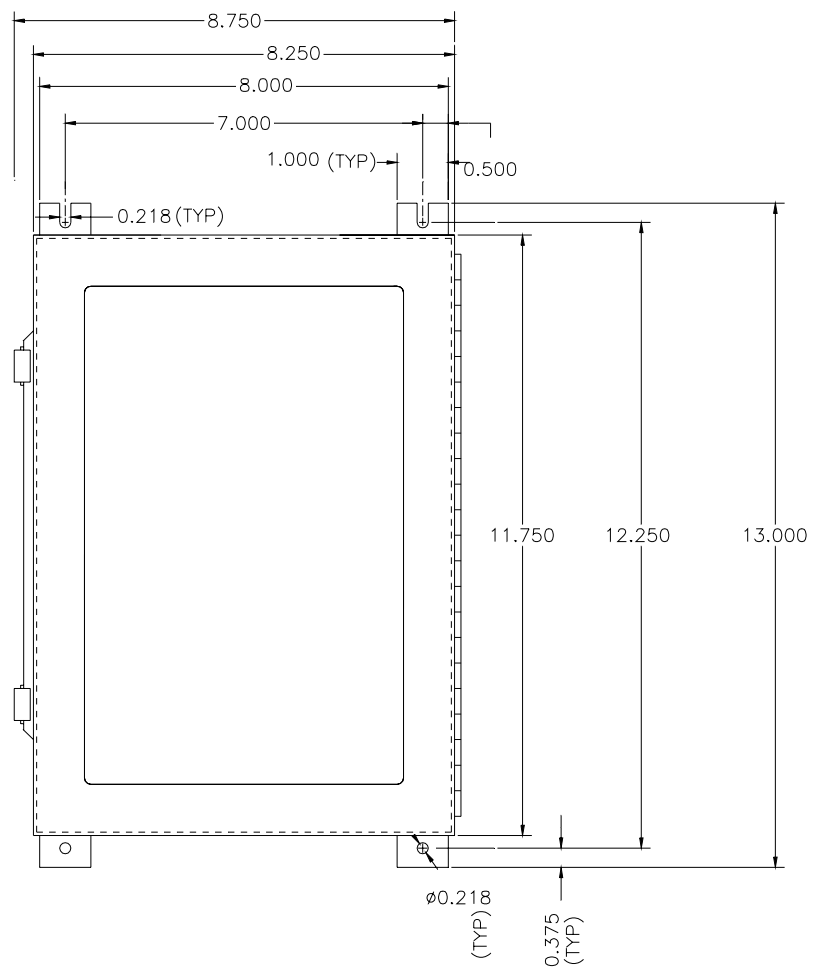

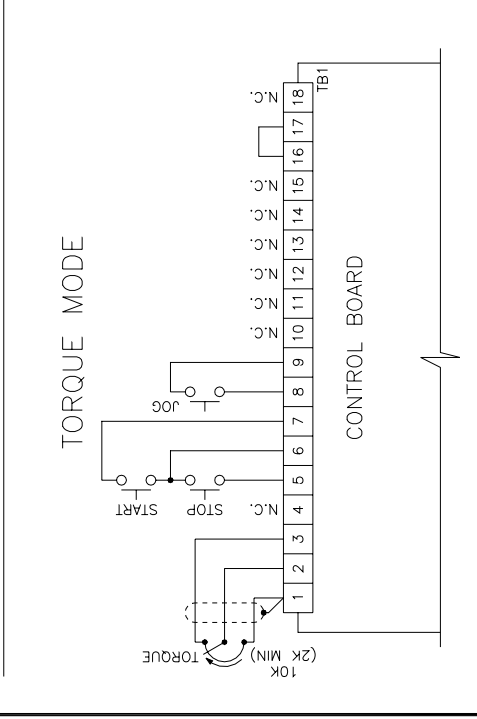
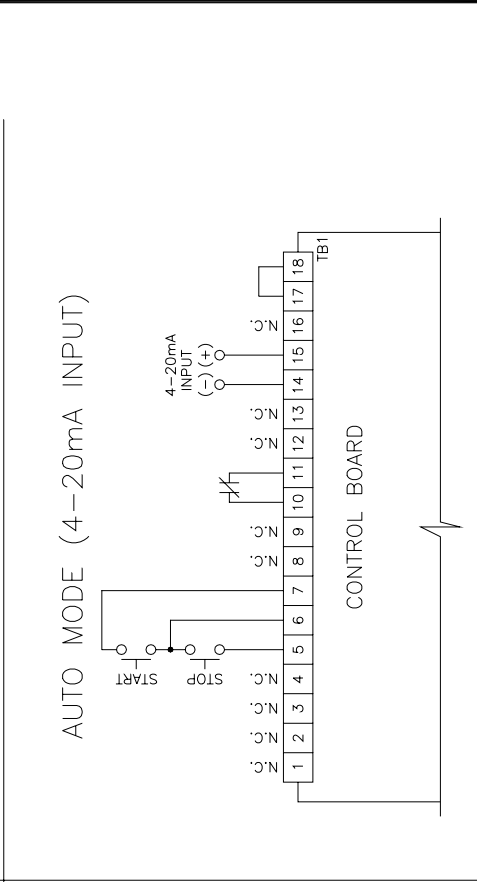
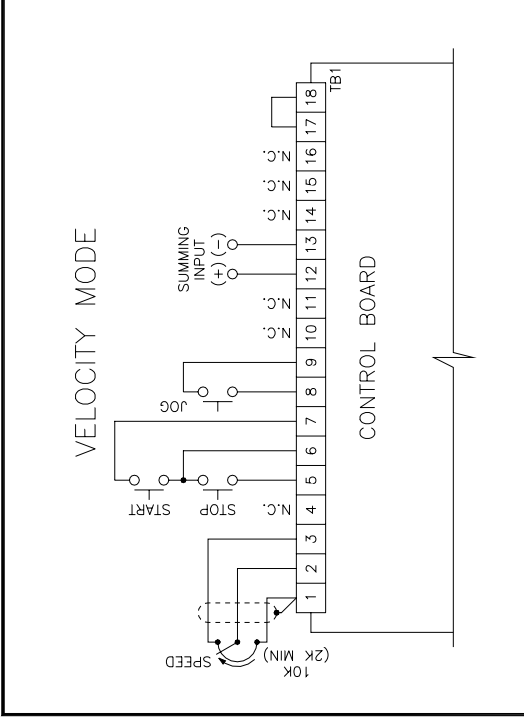
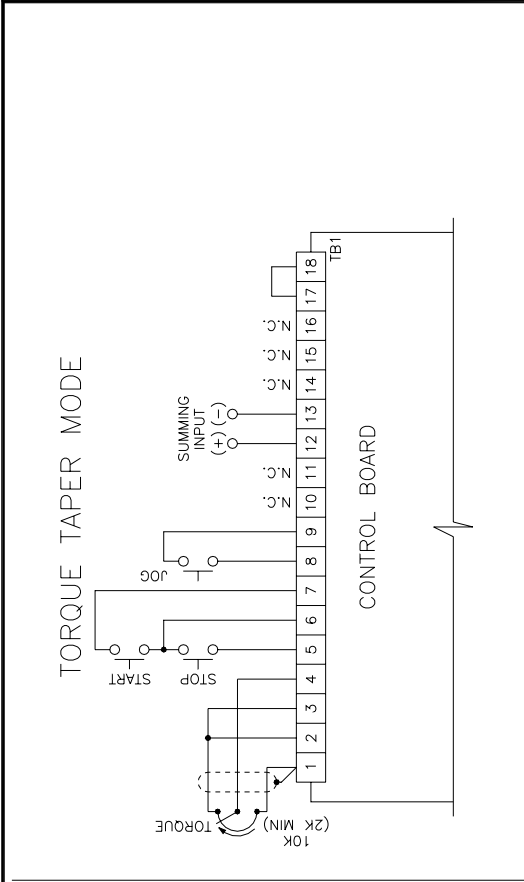

DRAWN BY:	DATE:
APPROVED BY:	1-8-91
DATE:	
TOLERANCES: ±	
3 DEC. PL.	
HEATH SPRINGS, SC	
FAX 803-288-8003	
TITLE:	
CONTROL BOARD CONNECTIONS	
SCALE: ---	
DRAWING NUMBER:	
C10635 REV. SH. 1 OF 1	

HEATH SPRINGS, SC
FAX 803-288-8003

TITLE: CONTROL BOARD CONNECTIONS

DRAWING NUMBER: C10635 REV. SH. 1 OF 1

230VAC INPUT WITH ENCODER FEEDBACK (300PPR)

NOTE: ENCODER FEEDBACK CAN ALSO BE USED WITH 115VAC INPUT
 CONTROL BD.
 J2=EFB
 POWER BD.
 J3=230V
 J4=230V
 J6=230V
 J7=300PPR

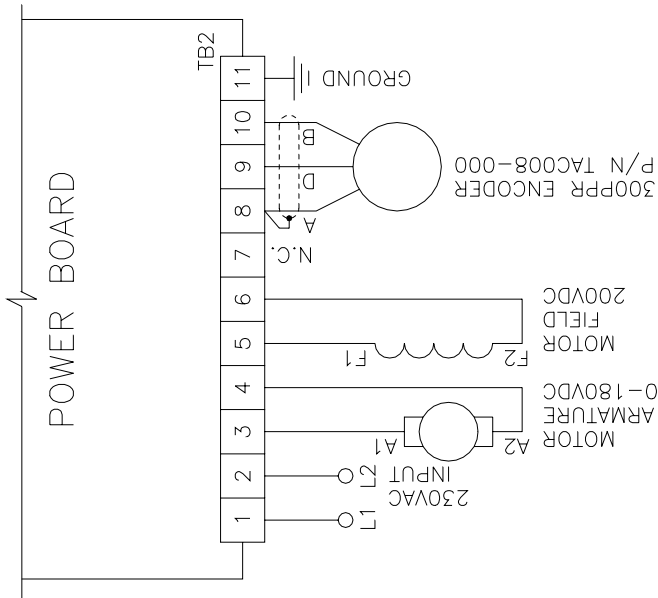

115VAC INPUT WITH TACH FEEDBACK (7V/1000RPM)

NOTE: TACH FEEDBACK CAN ALSO BE USED WITH 230VAC INPUT
 CONTROL BD.
 J2=TFB
 POWER BD.
 J3=115V
 J4=115V
 J6=115V
 J8=7V

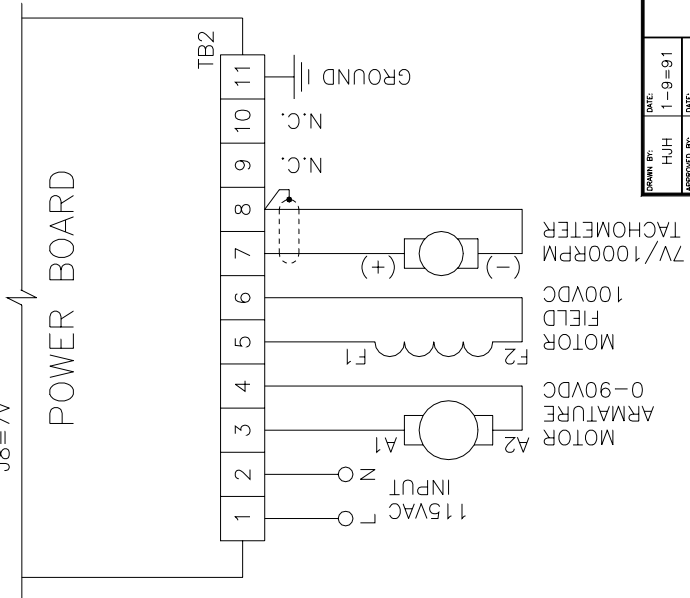

DRAWN BY:	DATE:	HEATH SPRINGS, SC
HJH	1-9-91	TEL: 803-286-8614
APPROVED BY:	DATE:	FAX: 803-286-6063
TOLERANCES:	TITLE: MOTOR AND AC POWER CONNECTIONS (FEEDBACK-ARMATURE, FIELD)	
2 DEC. PL.	SCALE: ---	
3 DEC. PL.	DRAWING NUMBER: C10636 REV. SH. 1 OF 1	

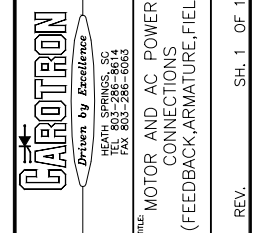

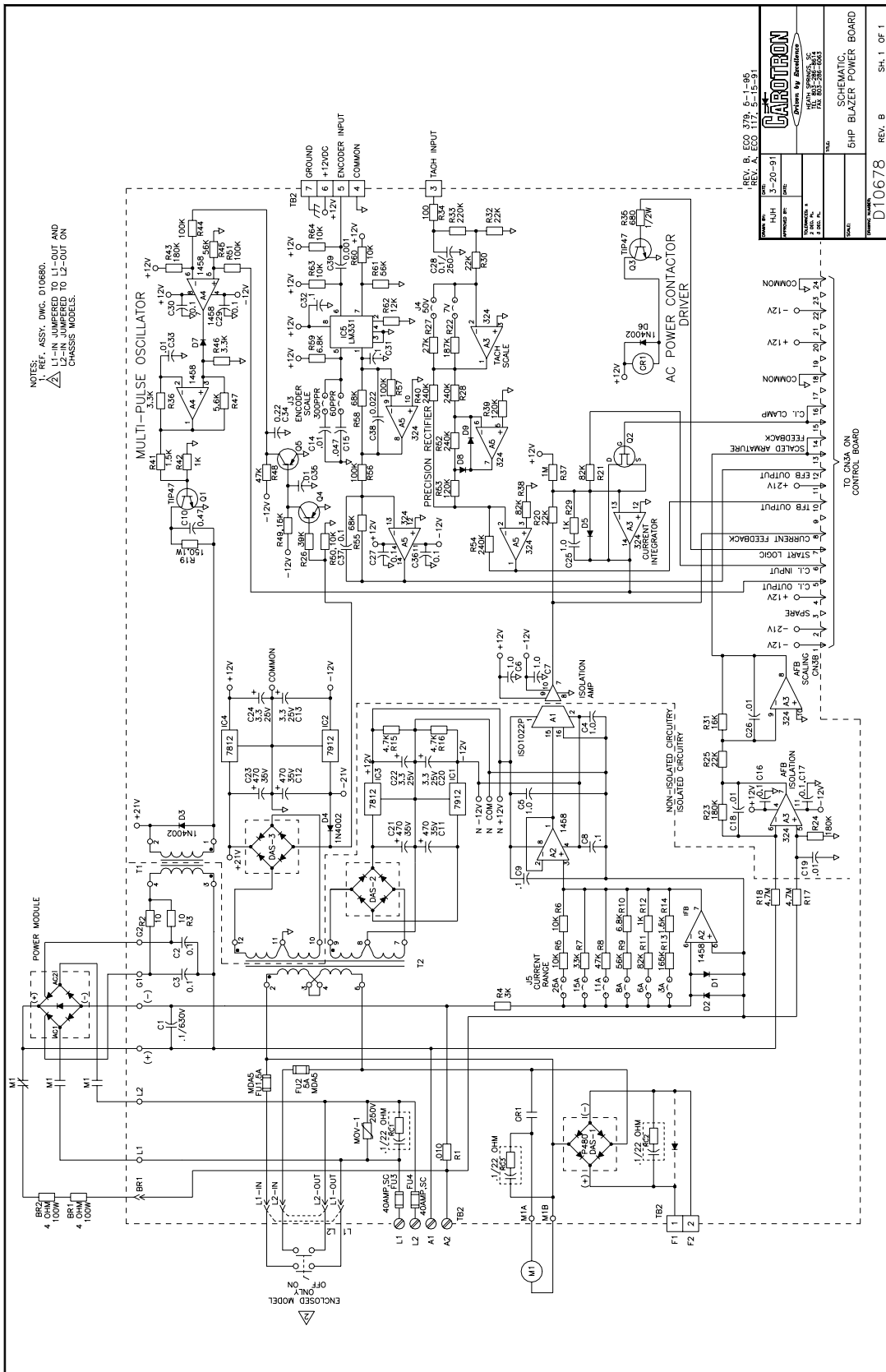

NOTES:
 1. ASSY. DWG. D10680.
 2. L1-IN JUMPERED TO L1-OUT AND L2-IN JUMPERED TO L2-OUT ON CHASSIS MODELS.

REV. B, ECO 379, 5-1-86
 REV. A, ECO 117, 5-1-81

		DATE	BY
		REV. NO.	REV. DATE
DRAWN BY: J. H. H. 3-20-81		CHECKED BY: J. H. H. 3-20-81	
PART NO.: 100-100-000		REV. NO.: 100-100-000	
TITLE: 5HP BLAZER POWER BOARD		SHEET NO.: SH. 1 OF 1	

D10678 REV. B

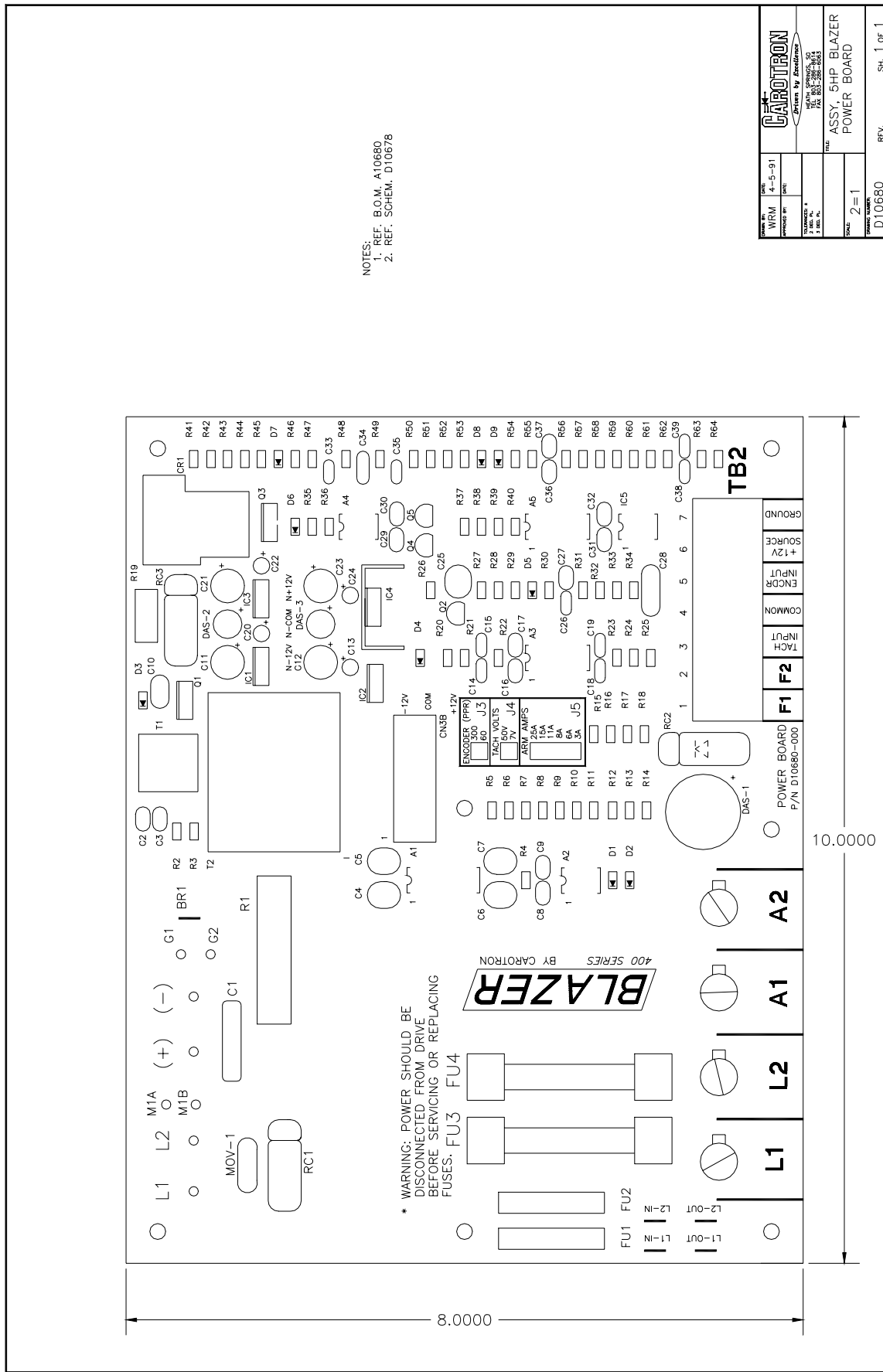

NOTES:
 1. REF. B.O.M. A10680
 2. REF. SCHEM. D10678

DATE:	4-5-91
DESIGNED BY:	WRM
CHECKED BY:	
DATE:	
ISSUED BY:	
REV.:	2=1
REV.:	D10680
REV.:	SH. 1 OF 1

CAROTRON
 Patent by Enclosures

THE ASSY. SHIP BLAZER
 POWER BOARD

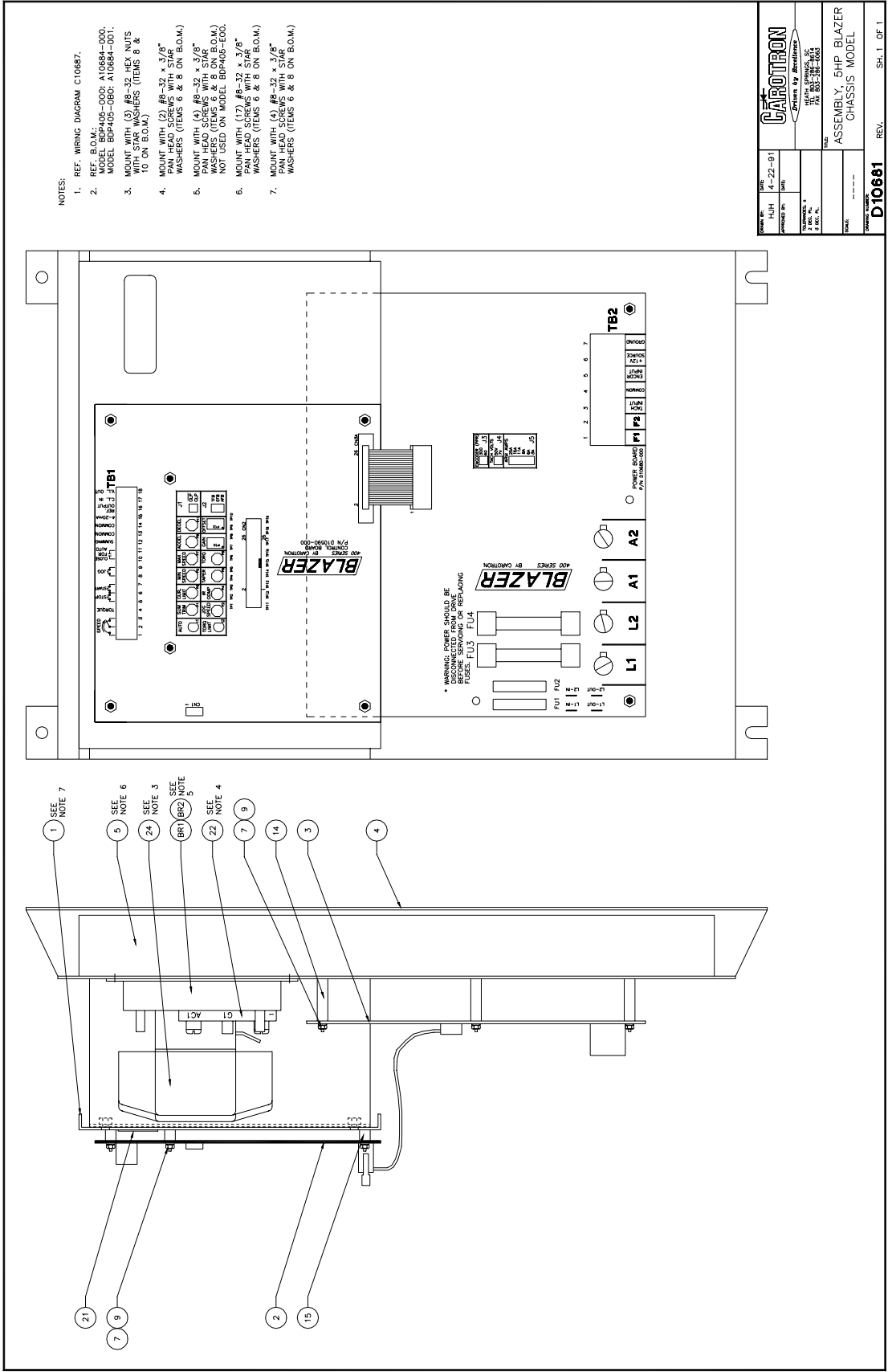

- NOTES:
1. REF. WIRING DIAGRAM C10687.
 2. REF. B.O.M.: 405-000; A10684-000. MODEL BDP405-000; A10684-001.
 3. MOUNT WITH (3) #8-32 HEX NUTS WITH STAR WASHERS (ITEMS 8 & 10 ON B.O.M.)
 4. MOUNT WITH (2) #8-32 x 3/8" PAN HEAD SCREWS WITH STAR WASHERS (ITEMS 6 & 8 ON B.O.M.)
 5. MOUNT WITH (4) #8-32 x 3/8" PAN HEAD SCREWS WITH STAR WASHERS (ITEMS 6 & 8 ON B.O.M.) NOT USED ON MODEL BDP405-000.
 6. MOUNT WITH (17) #8-32 x 3/8" PAN HEAD SCREWS WITH STAR WASHERS (ITEMS 6 & 8 ON B.O.M.)
 7. MOUNT WITH (4) #8-32 x 3/8" PAN HEAD SCREWS WITH STAR WASHERS (ITEMS 6 & 8 ON B.O.M.)

FORM NO.	DATE	REV.	SH. 1 OF 1
FUJH	4-22-91		
DESIGNED BY	DATE		
APPROVED BY	DATE		
CARBONTRON CARBON PAPER TECHNOLOGY			
HEAT SENSORS, INC. 1000 W. 10TH ST. DENVER, CO 80202-2803			
ASSEMBLY, 6HP BLAZER CHASSIS MODEL			
D10681			

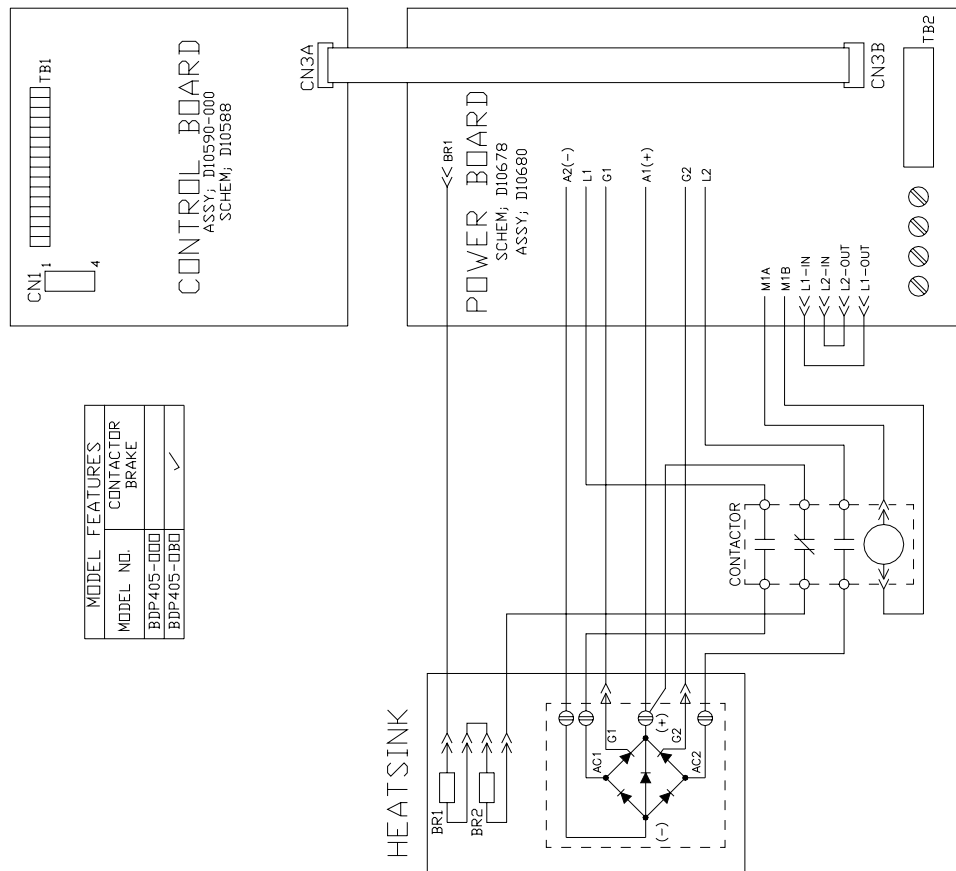

MODEL FEATURES	
MODEL NO.	CONTACTOR BRAKE
BDP405-000	
BDP405-0B0	✓

DESIGNER: HJH	DATE: 5-16-91
APPROVED BY:	DATE:
GAROTRON <i>Driven by Excellence</i>	
HEATH SPRINGS, SC TEL: 803-286-8614 FAX: 803-286-8003	
TITLE: WIRING DIAGRAM, SHP BLAZER CHASSIS MODELS	
SCALE: ---	REV. C10682
DRAWING NUMBER:	SH:1 OF:1

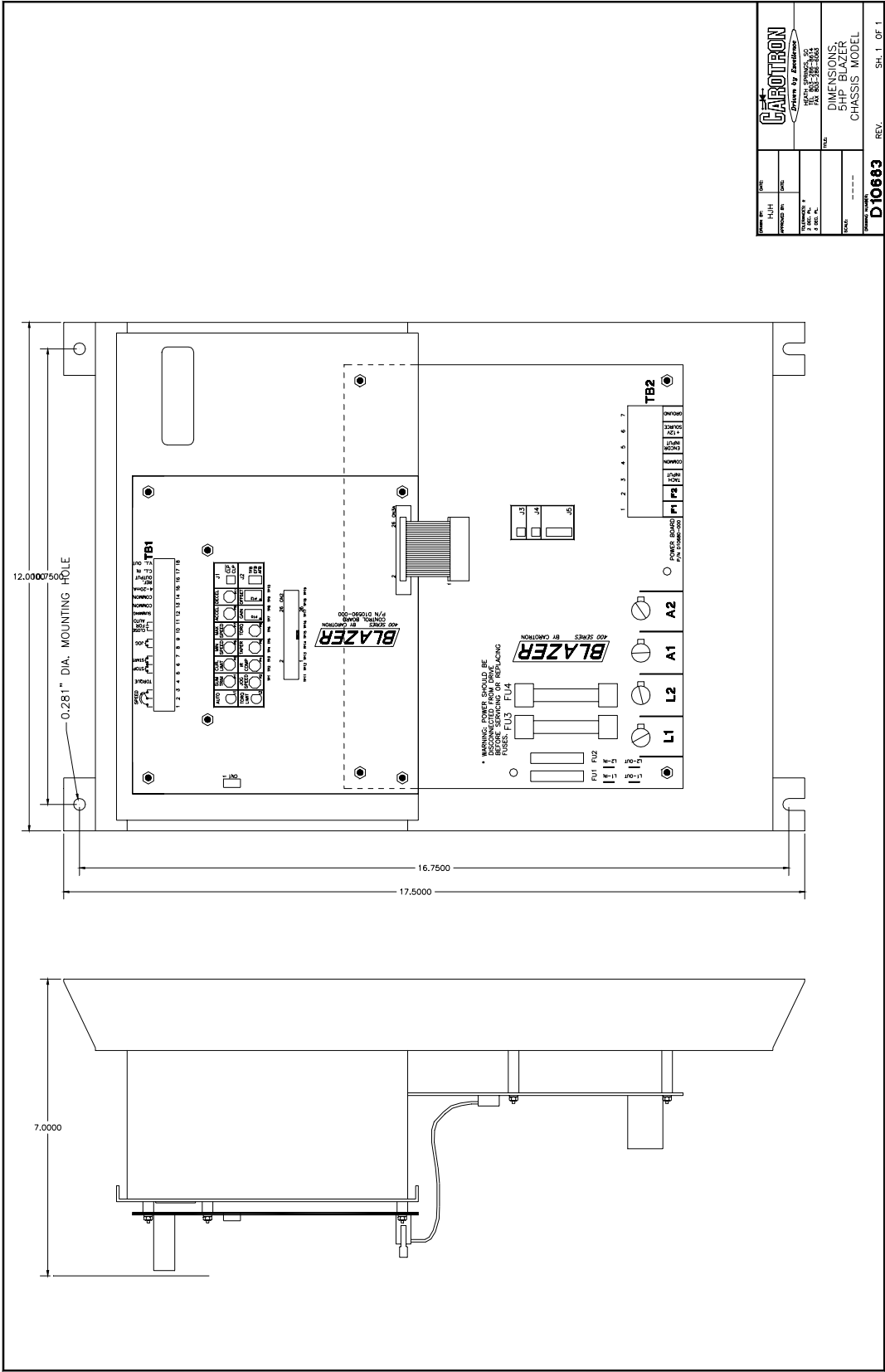

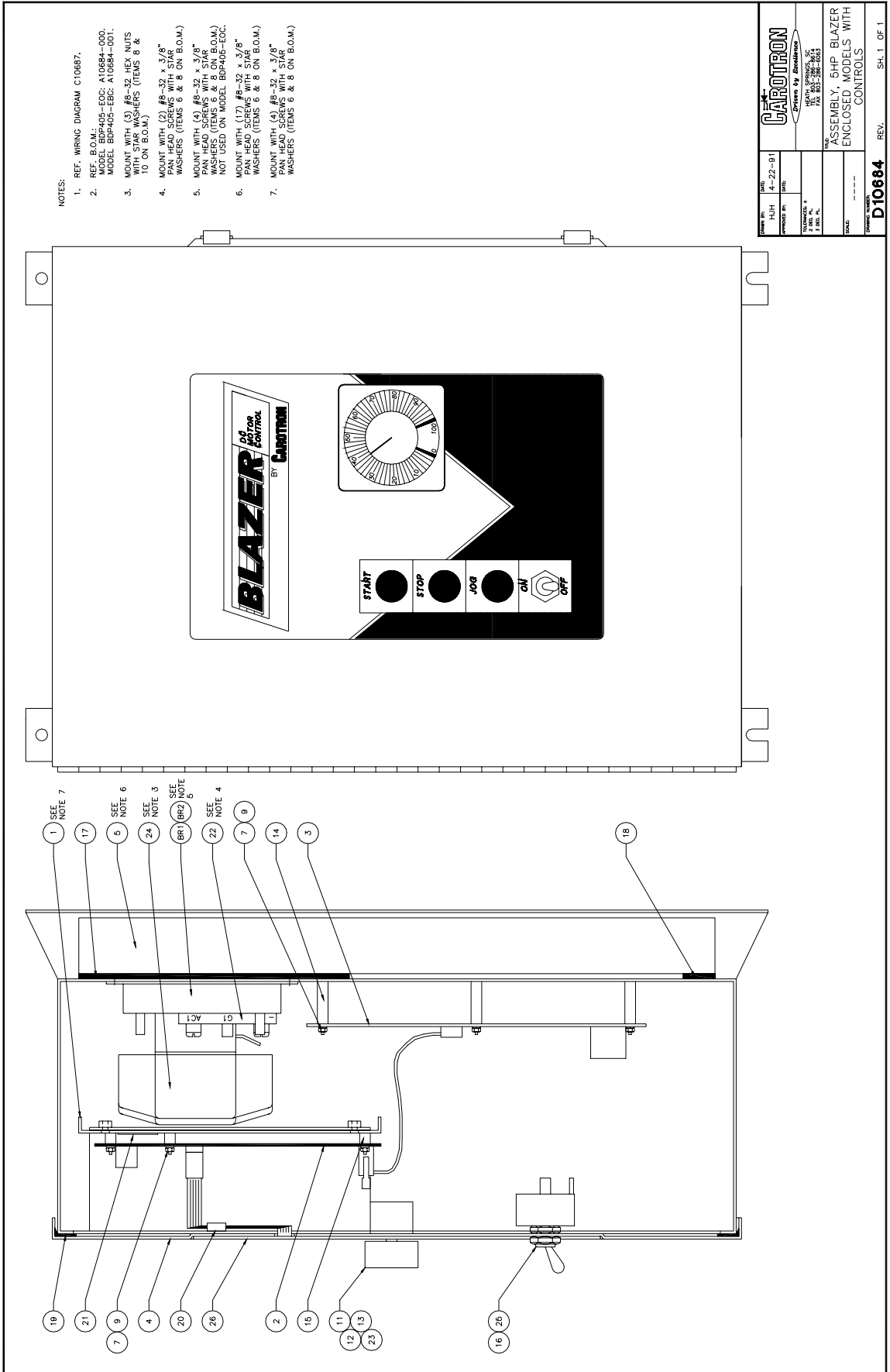

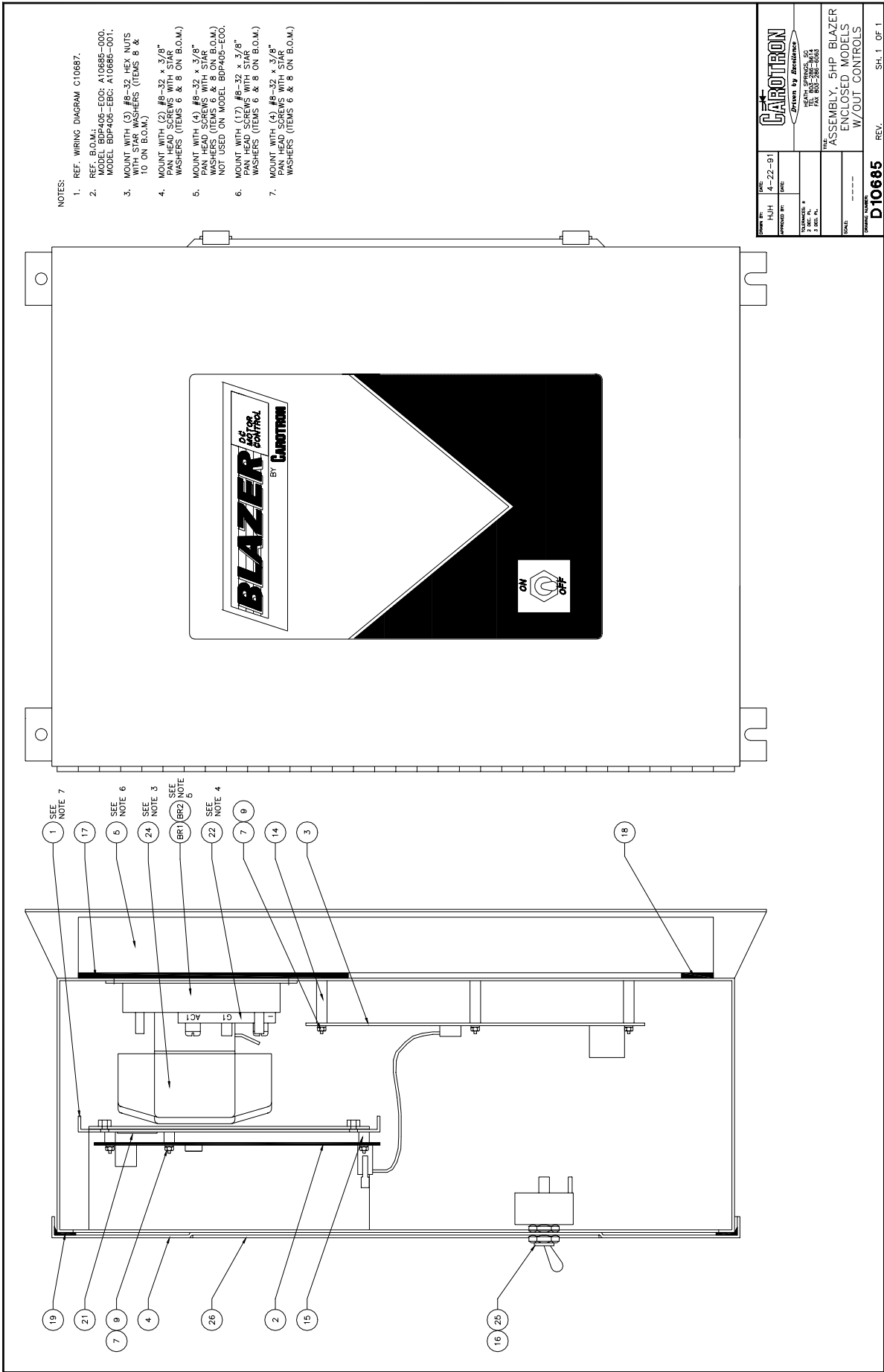

NOTES:

1. REF. WIRING DIAGRAM C10687.
2. REF. B.O.M.:
MODEL BDP405-EOO; A10685-000.
MODEL BDP405-EBC; A10685-001.
3. MOUNT WITH (3) #8-32 HEX NUTS
WITH STAR WASHERS (ITEMS 8 &
10 ON B.O.M.)
4. MOUNT WITH (2) #8-32 x 3/8"
PAN HEAD SCREWS WITH STAR
WASHERS (ITEMS 6 & 8 ON B.O.M.)
5. MOUNT WITH (4) #8-32 x 3/8"
PAN HEAD SCREWS WITH STAR
WASHERS (ITEMS 11, 12, 13 &
14 NOT USED ON MODEL BDP405-EOO.
6. MOUNT WITH (17) #8-32 x 3/8"
PAN HEAD SCREWS WITH STAR
WASHERS (ITEMS 6 & 8 ON B.O.M.)
7. MOUNT WITH (4) #8-32 x 3/8"
PAN HEAD SCREWS WITH STAR
WASHERS (ITEMS 6 & 8 ON B.O.M.)

FORM NO.	DATE	REV.
H/JH	4-22-91	
APPROVED BY:	DATE:	
CAROTRON <small>Driven by Excellence</small>		
<small>HEATH SPRINGS, SC P.O. BOX 2886 29928-2886</small>		
NAME: ASSEMBLY 5HP BLAZER ENCLOSED MODELS W/OUT CONTROLS		
D10685		
PART NUMBER		REV.
		SH. 1 OF 1

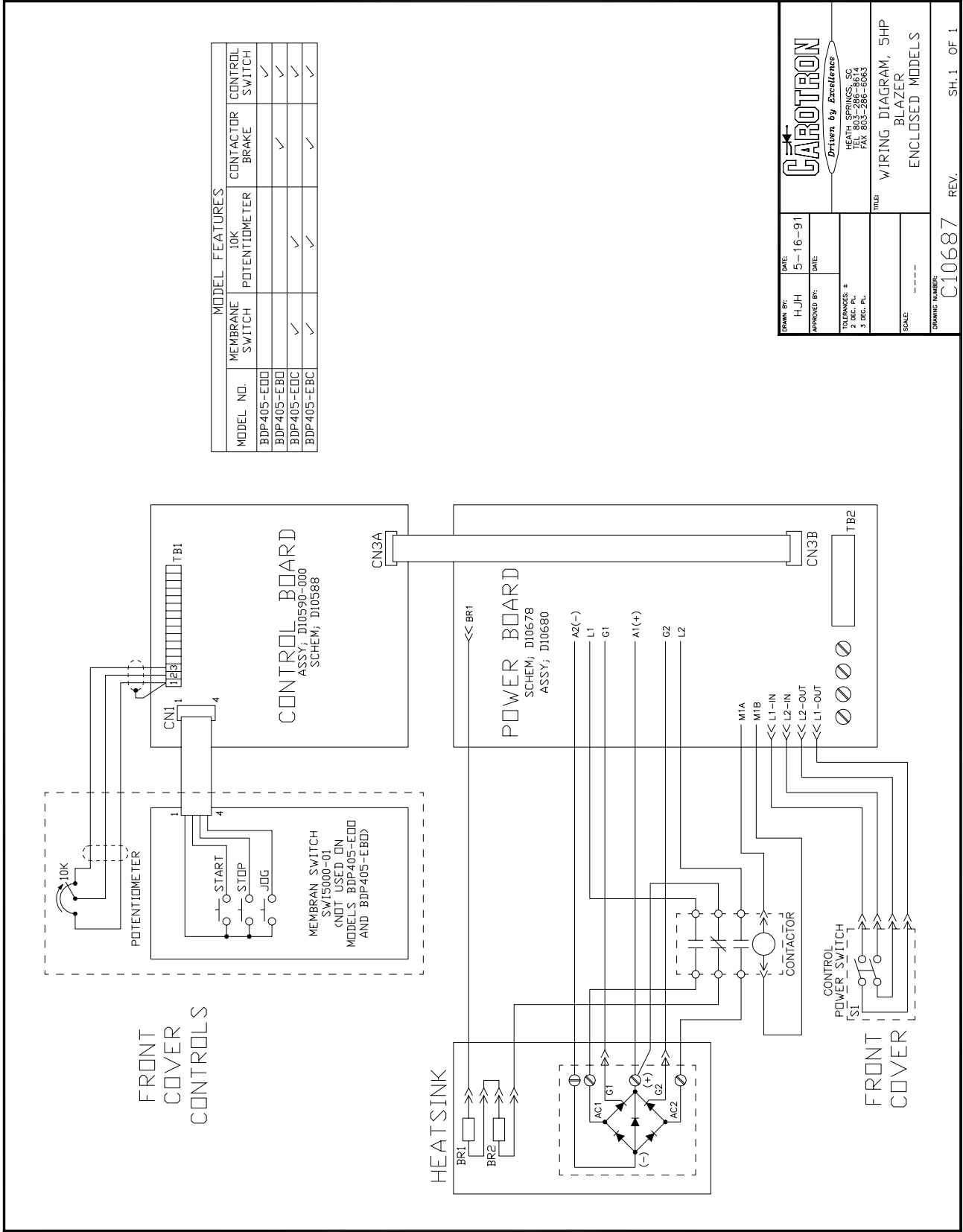

MODEL FEATURES

MODEL NO.	MEMBRANE SWITCH	IOK POTENTIOMETER	CONTACTOR BRAKE	CONTROL SWITCH
BDP405-E00				✓
BDP405-EB0		✓		✓
BDP405-E0C	✓	✓		✓
BDP405-EBC	✓	✓	✓	✓

CAROTRON <i>Driven by Excellence</i> HEATH SPRINGS, SC TEL. 803-286-8614 FAX. 803-286-8663	DATE: 5-16-91 DRAWN BY: H-JH APPROVED BY:
TOLERANCES # 1 DEC. PL. 2 DEC. PC. 3 DEC. FC.	SCALE: ----
DRAWING NUMBER: C10687 REV.	SH.1 OF 1

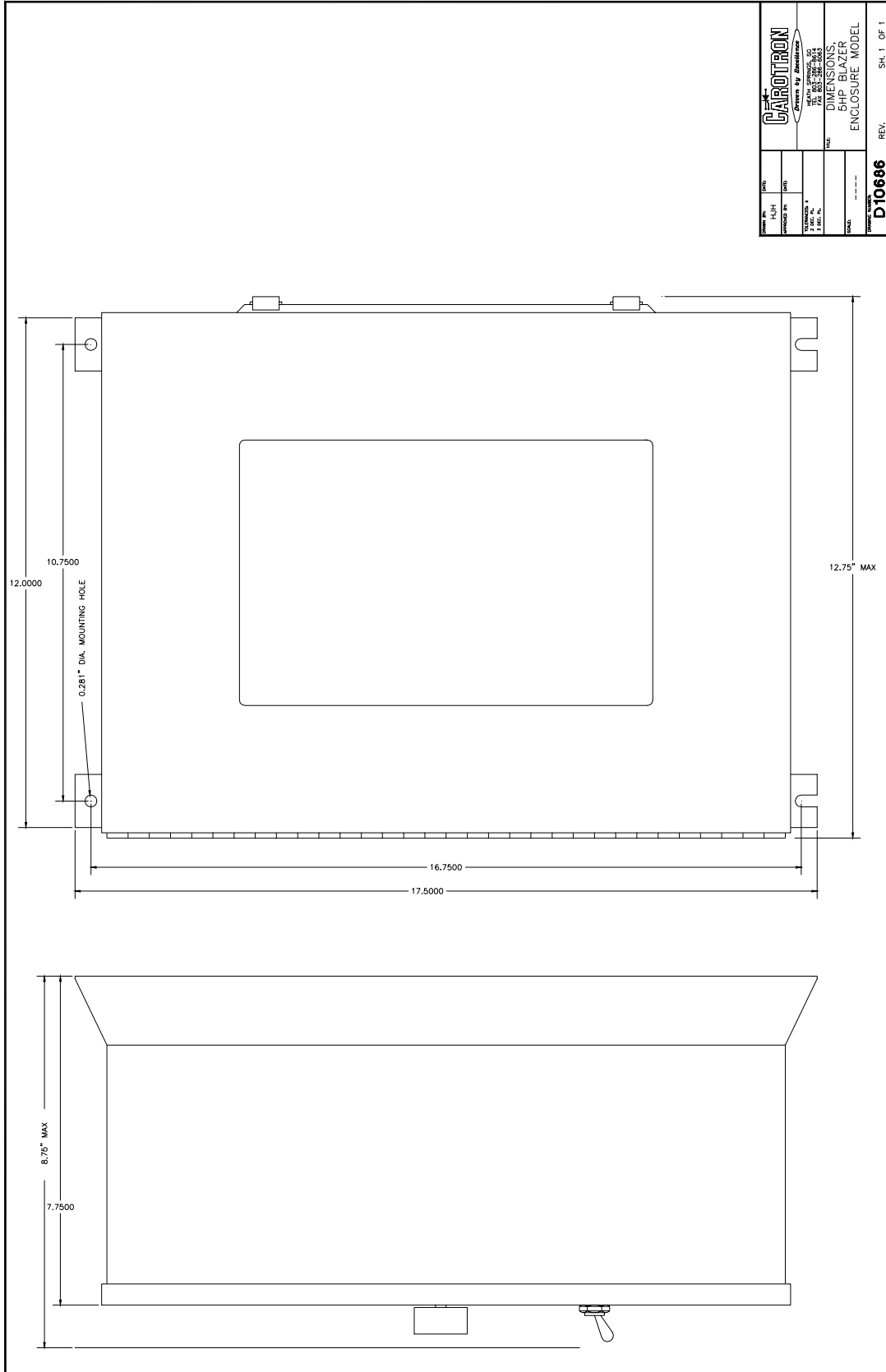

DATE	REV.	BY	CHKD.
11/11/00	1	HLH	HLH
 Carotron Precision by Assembly			
DIMENSIONS: SHP BLAZER ENCLOSURE MODEL			
DRAWING NUMBER: D10686			
REV. SH. 1 OF 1			

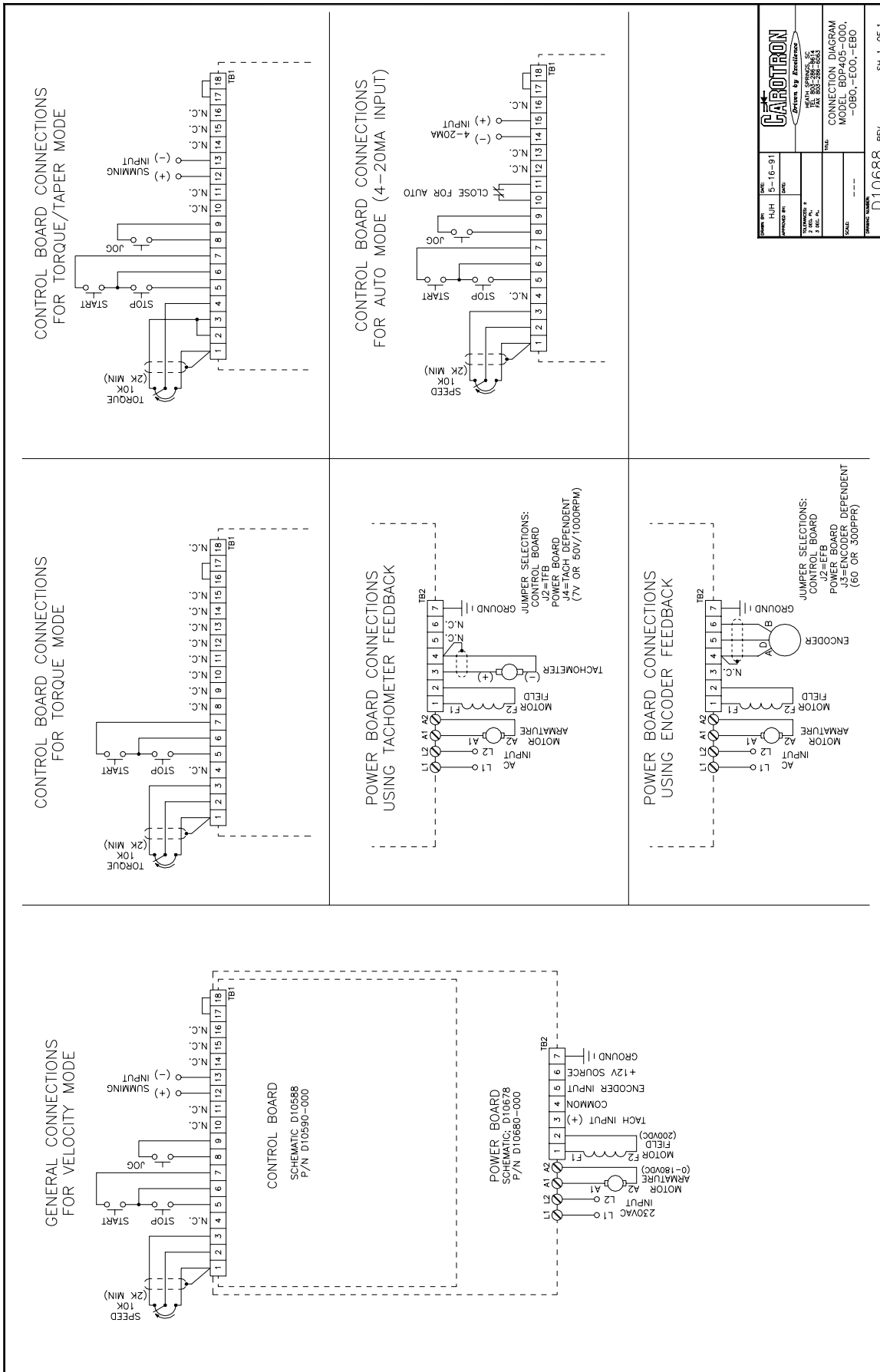

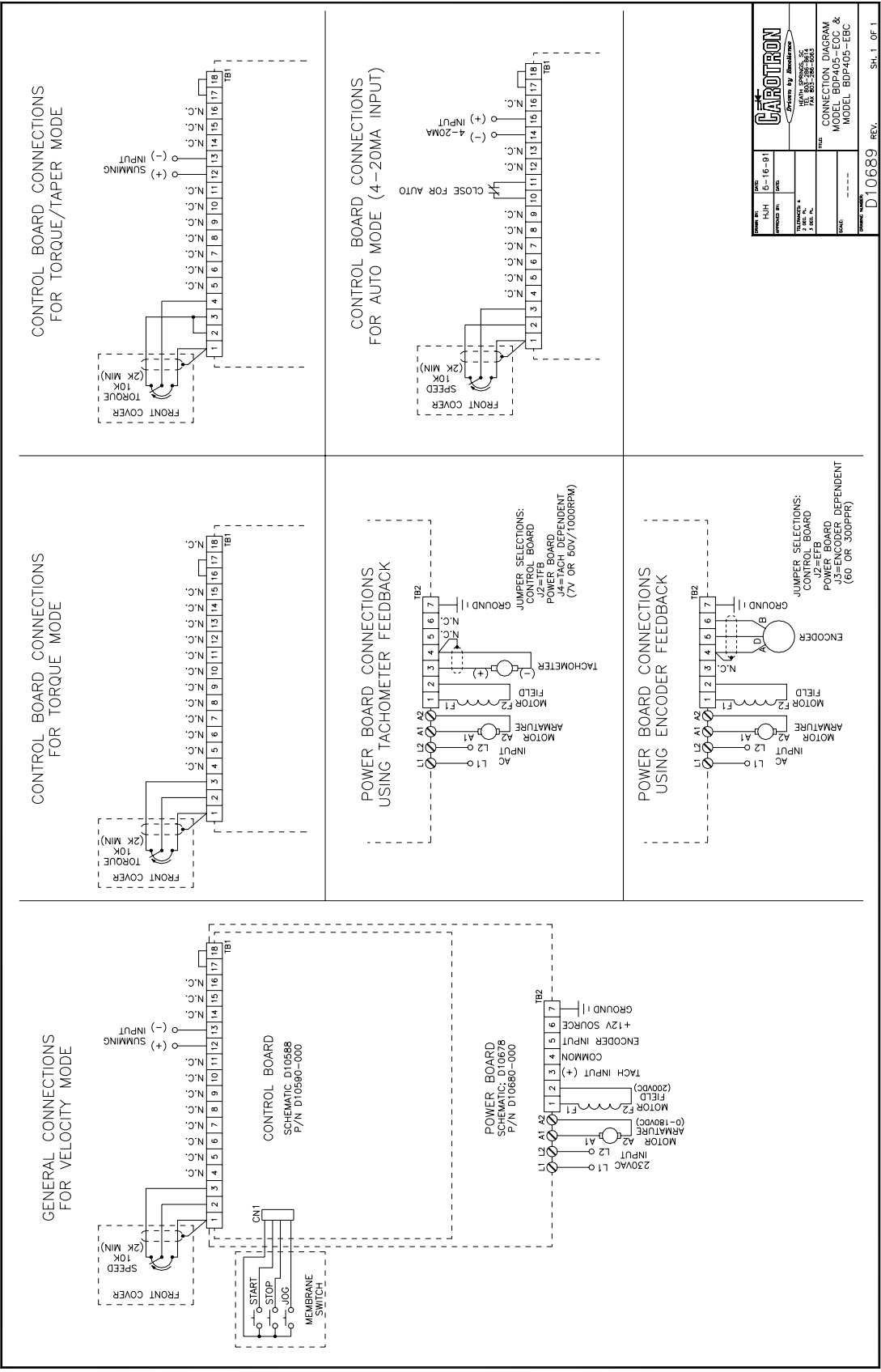

Notes:

Standard Terms & Conditions of Sale

1. General

The Standard Terms and Conditions of Sale of Carotron, Inc. (hereinafter called "Company") are set forth as follows in order to give the Company and the Purchaser a clear understanding thereof. No additional or different terms and conditions of sale by the Company shall be binding upon the Company unless they are expressly consented to by the Company in writing. The acceptance by the Company of any order of the Purchaser is expressly conditioned upon the Purchaser's agreement to said Standard Terms and Conditions. The acceptance or acknowledgement, written, oral, by conduct or otherwise, by the Company of the Purchaser's order shall not constitute written consent by the Company to addition to or change in said Standard Terms and Conditions.

2. Prices

Prices, discounts, allowances, services and commissions are subject to change without notice. Prices shown on any Company published price list and other published literature issued by the Company are not offers to sell and are subject to express confirmation by written quotation and acknowledgement. All orders of the Purchaser are subject to acceptance, which shall not be effective unless made in writing by an authorized Company representative at its office in Heath Springs, S.C. The Company may refuse to accept any order for any reason whatsoever without incurring any liability to the Purchaser. The Company reserves the right to correct clerical and stenographic errors at any time.

3. Shipping dates

Quotation of a shipping date by the Company is based on conditions at the date upon which the quotation is made. Any such shipping date is subject to change occasioned by agreements entered into previous to the Company's acceptance of the Purchaser's order, governmental priorities, strikes, riots, fires, the elements, explosion, war, embargoes, epidemics, quarantines, acts of God, labor troubles, delays of vendors or of transportation, inability to obtain raw materials, containers or transportation or manufacturing facilities or any other cause beyond the reasonable control of the Company. In no event shall the Company be liable for consequential damages for failure to meet any shipping date resulting from any of the above causes or any other cause.

In the event of any delay in the Purchaser's accepting shipment of products or parts in accordance with scheduled shipping dates, which delay has been requested by the Purchaser, or any such delay which has been caused by lack of shipping instructions, the Company shall store all products and parts involved at the Purchaser's risk and expense and shall invoice the Purchaser for the full contract price of such products and parts on the date scheduled for shipment or on the date on which the same is ready for delivery, whichever occurs later.

4. Warranty

The Company warrants to the Purchaser that products manufactured or parts repaired by the Company, will be free, under normal use and maintenance, from defects in material and workmanship for a period of one (1) year after the shipment date from the Company's factory to the Purchaser. The Company makes no warranty concerning products manufactured by other parties.

As the Purchaser's sole and exclusive remedy under said warranty in regard to such products and parts, including but not limited to remedy for consequential damages, the Company will at its option, repair or replace without charge any product manufactured or part repaired by it, which is found to the Company's satisfaction to be so defective; provided, however, that (a) the product or part involved is returned to the Company at the location designated by the Company, transportation charges prepaid by the Purchaser; or (b) at the Company's option the product or part will be repaired or replaced in the Purchaser's plant; and also provided that (c) the Company is notified of the defect within one (1) year after the shipment date from the Company's factory of the product or part so involved.

The Company warrants to the Purchaser that any system engineered by it and started up under the supervision of an authorized Company representative will, if properly installed, operated and maintained, perform in compliance with such system's written specifications for a period of one (1) year from the date of shipment of such system.

As the Purchaser's sole and exclusive remedy under said warranty in regard to such systems, including but not limited to remedy for consequential damages, the Company will, at its option, cause, without charges any such system to so perform, which system is found to the Company's satisfaction to have failed to so perform, or refund to the Purchaser the purchase price paid by the Purchaser to the Company in

regard thereto; provided, however, that (a) Company and its representatives are permitted to inspect and work upon the system involved during reasonable hours, and (b) the Company is notified of the failure within one (1) year after date of shipment of the system so involved.

The warranties hereunder of the Company specifically exclude and do not apply to the following:

a. Products and parts damaged or abused in shipment without fault of the Company.

b. Defects and failures due to operation, either intentional or otherwise, (1) above or beyond rated capacities, (2) in connection with equipment not recommended by the Company, or (3) in an otherwise improper manner.

c. Defects and failures due to misapplication, abuse, improper installation or abnormal conditions of temperature, humidity, abrasives, dirt or corrosive matter.

d. Products, parts and systems which have been in any way tampered with or altered by any party other than an authorized Company representative.

e. Products, parts and systems designed by the Purchaser.

f. Any party other than the Purchaser.

The Company makes no other warranties or representation, expressed or implied, of merchantability and of fitness for a particular purpose, in regard to products manufactured, parts repaired and systems engineered by it.

3. Terms of payment

Standard terms of payment are net thirty (30) days from date of the Company invoice. For invoice purposed, delivery shall be deemed to be complete at the time the products, parts and systems are shipped from the Company and shall not be conditioned upon the start up thereof. Amounts past due are subject to a service charge of 1.5% per month or fraction thereof.

6. Order cancellation

Any cancellation by the Purchaser of any order or contract between the Company and the Purchaser must be made in writing and receive written approval of an authorized Company representative at its office in Heath Springs, S.C. In the event of any cancellation of an order by either party, the Purchaser shall pay to the Company the reasonable costs, expenses, damages and loss of profit of the Company incurred there by, including but not limited to engineering expenses and expenses caused by commitments to the suppliers of the Company's subcontractors, as determined by the Company.

7. Changes

The Purchaser may, from time to time, but only with the written consent of an authorized Company representative, make a change in specifications to products, parts or systems covered by a purchase order accepted by the company. In the event of any such changes, the Company shall be entitled to revise its price and delivery schedule under such order.

8. Returned material

If the Purchaser desires to return any product or part, written authorization thereof must first be obtained from the Company which will advise the Purchaser of the credit to be allowed and restocking charges to be paid in regard to such return. No product or part shall be returned to the Company without a "RETURN TAG" attached thereon which has been issued by the Company.

9. Packing

Published prices and quotations include the Company's standard packing for domestic shipment. Additional expenses for special packing or overseas shipments shall be paid by the Purchaser. If the Purchaser does not specify packing or accepts parts unpacked, no allowance will be made to the Purchaser in lieu of packing.

10. Standard transportation policy

Unless expressly provided in writing to the contrary, products, parts and systems are sold f.o.b. first point of shipment. Partial shipments shall be permitted, and the Company may invoice each shipment separately. Claims for non-delivery of products, parts and systems, and for damages thereto must be filed with the carrier by the Purchaser. The Company's responsibility therefor shall cease when the carrier signs for and accepts the shipment.

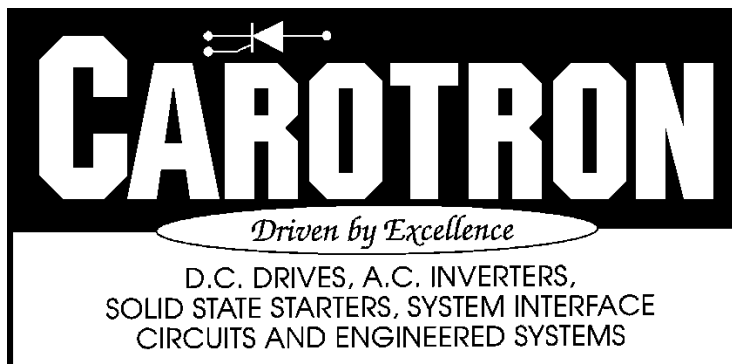

3204 Rocky River Road
Heath Springs, SC 29058
Phone: (803) 286-8614
Fax: (803) 286-6063
Email: saleserv@carotron.com
Web: www.carotron.com
MAN1007-2A
Issued 10-14-2004