



3204 Rocky River Road, Heath Springs, SC 29058
Phone: 803-286-8614 Fax: 803-286-6063

Blazer IV®

Series ¼ - 5hp Isolated Regen Drives

The Blazer IV Series of D.C. motor controls provide full-wave, four-quadrant regenerative speed or torque control for 1/4-5 HP shunt wound and permanent magnet D.C. motors.

The BRC700 models are loaded with standard features that only Carotron could provide reliably. One very important feature of the Blazer IV series is control circuit isolation. The control circuit of each model is completely isolated from the power circuit.

This isolation protects reference circuits and feedback circuits from possible damage due to accidental shorts to ground. Also, this standard isolation greatly simplifies master reference, tachometer follower and process control applications.

Another primary feature is an armature contactor for safety disconnect during normal stop conditions. Logic in the BLAZER IV control circuit assures that current flow to the motor has ceased prior to de-energizing the contactors. This reduces electrical stress and increases contactor life.

Encoder or pulse tachometer feedback is another key standard feature in the BLAZER IV Series. This feature allows frequency signals required for process monitoring to be used to improve speed regulation and simplify system requirements.

Other standard feedback methods available in each model are armature voltage or 7 and 50 VDC tachometers. An accessory drive circuit monitor, Model DCM100-000, is available to assist in set-up and troubleshooting by plugging into the control board to easily access 20 separate signals.

Additional features of the BLAZER IV SERIES are listed on the following pages. As you can see, these units are loaded with innovative features that can simplify your drive applications.



Standard Features

- Regenerative action provides four quadrant speed control
- Isolation amplifier for providing isolated armature current feedback
- Impedance isolation, 5 Meg Ohms, for armature voltage feedback isolation
- Tachometer and encoder feedback are insensitive to direction of motor rotation
- Encoder power supply, +12 VDC @ 100 mA, terminal strip accessible
- Jog Delay to allow rapid jogging without deenergizing the line contactor to extend contactor life
- Bridge delay circuitry built in to extend contactor life
- Terminal strip access to Accel/Decel output, Velocity Loop output and Current Loop input for systems interface
- Internal JOG pot for adjustment of Jog Speed
- Summing input with on board trim pot to allow voltage summing with speed reference
- Jumper selection to allow summing input to be clamped or not clamped in the Jog Mode
- Jumper selection to control summing input polarity

- 45° angle depluggable terminals for all customer connections except line, armature and field connections
- Terminal strip connections for Forward Run, Reverse Run, Forward Jog, Reverse Jog, Ramp Stop and Emergency Stop
- LED indicators for Power, Forward and Reverse directions
- DCM connector and signal test points for easy troubleshooting
- Inner current loop for fast stable response to load change
- Metal film resistors and cermet pots for temperature stability
- I.C. regulated power supplies
- High frequency multi-pulse gating
- Conservative power module rating
- R-C decoupling of signal level inputs for superior noise rejection
- AC line fuses
- Line MOV and snubber for transient protection
- Functional terminal strip labeling and logical P.C. board layout
- Independent adjustable linear acceleration and deceleration in both the forward and reverse directions
- Independent max speed for forward and reverse directions
- Independent current limit for forward and reverse directions
- Integral null adjustment
- Adjustable IR compensation
- Current range selectable by jumper Armature, encoder or tachometer feedback selectable by jumper
- Two tachometer feedback voltages selectable by jumper: 7 or 50 VDC per thousand RPM tach feedback
- 300 PPR encoder feedback
- Power On/Off switch for control circuit (enclosed models only)
- Membrane switch control panel for Run Forward, Run Reverse, Jog Forward, Jog Reverse and Ramp Stop. Mushroom style locking button for Emergency Stop (enclosed models with control panel only)
- NEMA 12 enclosure for enclosed models Armature contactor and Dynamic Braking for safety disconnect in stopped condition

Specifications

BRC 702 Models

A.C. INPUT

115 VAC \pm 10%, 50/60 Hz \pm 2 Hz

230 VAC \pm 10%, 50/60 Hz \pm 2 Hz

ARMATURE OUTPUT

0- 90 VDC for 115 VAC input

0-180 VDC for 230 VAC input

FIELD OUTPUT

100 VDC @ 1 Amp for 115 VAC input

200 VDC @ 1 Amp for 230 VAC input

HORSEPOWER RANGE

1/4 - 1 HP @ 90 VDC

1/2 - 2 HP @ 180 VDC

BRC 705 Models

A.C. INPUT

230 VAC \pm 10%, 50/60 Hz \pm 2 Hz

ARMATURE OUTPUT

0-180 VDC

FIELD OUTPUT

200 VDC @ 1 Amp

HORSEPOWER RANGE

1/2 - 5 HP @ 180 VDC

All Models

SPEED REGULATION

Armature feedback: \pm 1.0% of base speed

Tachometer or Encoder Feedback: \pm 0.5% of base speed

TORQUE REGULATION

\pm 2% of current range selected

ADJUSTMENTS

- Max Speed: -20 to +10% of full base speed

- Current Limit: 0 to 150% of current range selected

- IR Compensation: Range set by current limit jumper

- ACCEL and DECEL: linear, independently adjustable forward and reverse, 2 ranges, 1 - 8 sec. or 8 - 60 sec.

- Jog Speed: 0 - 25% of rated armature voltage

- Sum Trim: 0 - 150% of summing input

- Integral Null: null adjustment to eliminate motor creeping and backup

SPEED RANGE

20:1 motor dependent

TEMPERATURE RANGE

Chassis: 0 - 55°C

Enclosed: 0 - 40°C

Standard Models and Descriptions

115 VAC Input	230VAC Input	Model Number	Description	Approx. Shpg. Wt.	Dim.	Conn.
¼ - 1 HP	½ - 2 HP	BRC702-000	Chassis Only, Basic Model	11 lbs.	E.1	E.5
---	½ - 5 HP	BRC705-000	Chassis Only, Basic Model	20 lbs.	E.3	E.6
¼ - 1 HP	½ - 2 HP	BRC702-E00	NEMA 12 Enclosed Model with E-Stop, and Power On/Off Switch	22 lbs.	E.2	E.5
---	½ - 5 HP	BRC705-E00	NEMA 12 Enclosed Model with E-Stop, and Power On/Off Switch	30	E.4	E.6
¼ - 1 HP	½ - 2 HP	BRC702-E0C	NEMA 12 Enclosed Model with Fwd, Rev, Jog Fwd, Jog Rev, E-Stop, Stop and Power On/Off Switch	22	E.2	E.5
---	½ - 5 HP	BRC705-E0C	NEMA 12 Enclosed Model with Speed Pot, Fwd, Rev, Jog Fwd, Jog Rev, E-Stop, Stop and Power On/Off Switch	30	E.4	E.6
¼ - 1 HP	½ - 2 HP	BRC702-0B0	Run Brake Model, Chassis Only	11	E.1	E.5
---	½ - 5 HP	BRC705-0B0	Run Brake Model, Chassis Only	20	E.3	E.6
¼ - 1 HP	½ - 2 HP	BRC702-EB0	NEMA 12 Enclosed Run-Brake Model with E-Stop and Power On/Off Switch	22	E.2	E.5
---	½ - 5 HP	BRC705-EB0	NEMA 12 Enclosed Run-Brake Model with E-Stop and Power On/Off Switch	30	E.4	E.6
¼ - 1 HP	½ - 2 HP	BRC702-EBC	NEMA 12 Enclosed Run-Brake Model with Speed Pot, Fwd, Rev, Jog Fwd, Jog Rev, E-Stop, Stop, and Power On/Off Switch	22	E.2	E.5
---	½ - 5 HP	BRC705-EBC	NEMA 12 Enclosed Run-Brake Model with Speed Pot, Fwd, Rev, Jog Fwd, Jog Rev, E-Stop, Stop and Power On/Off Switch	30	E.4	E.6

Dimensions

2HP Chassis Models

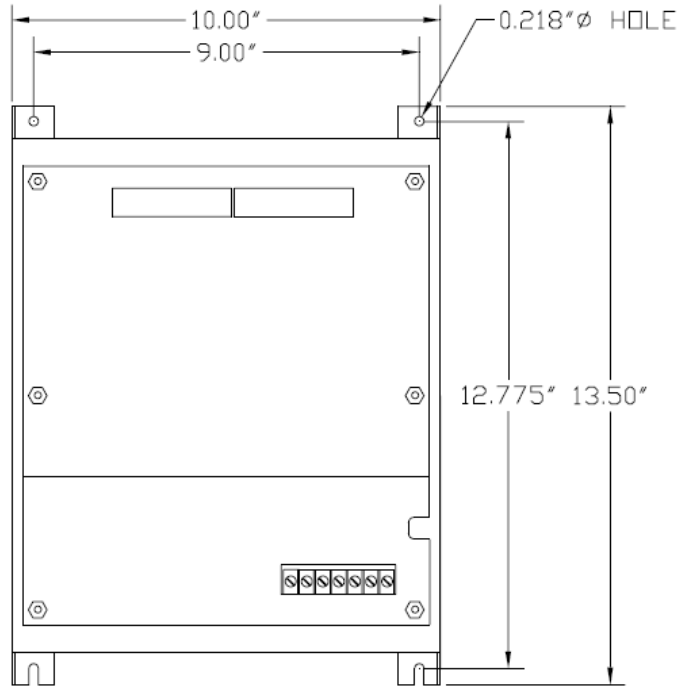
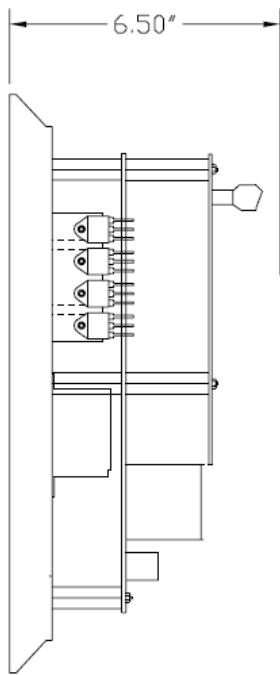

Fig. E.1

2HP Enclosed Models

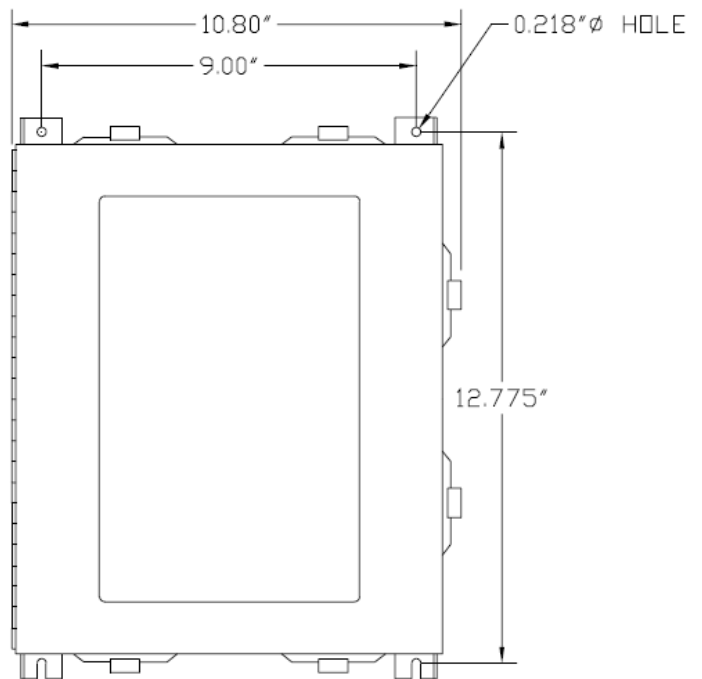
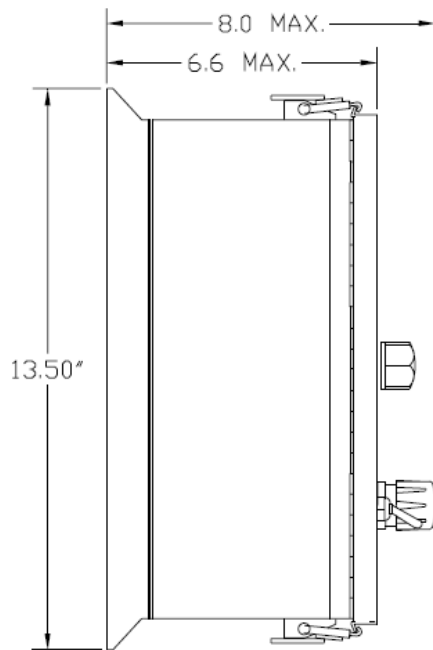

Fig. E.2

Dimensions

5 HP Chassis Models

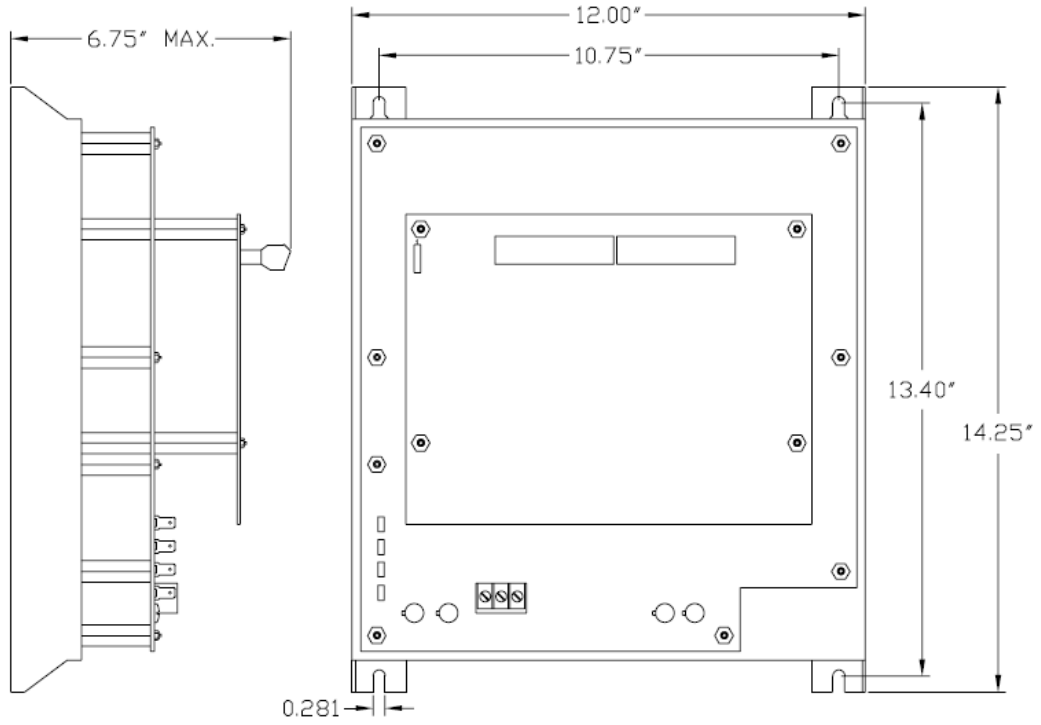

Fig. E.3

5HP Enclosed Models

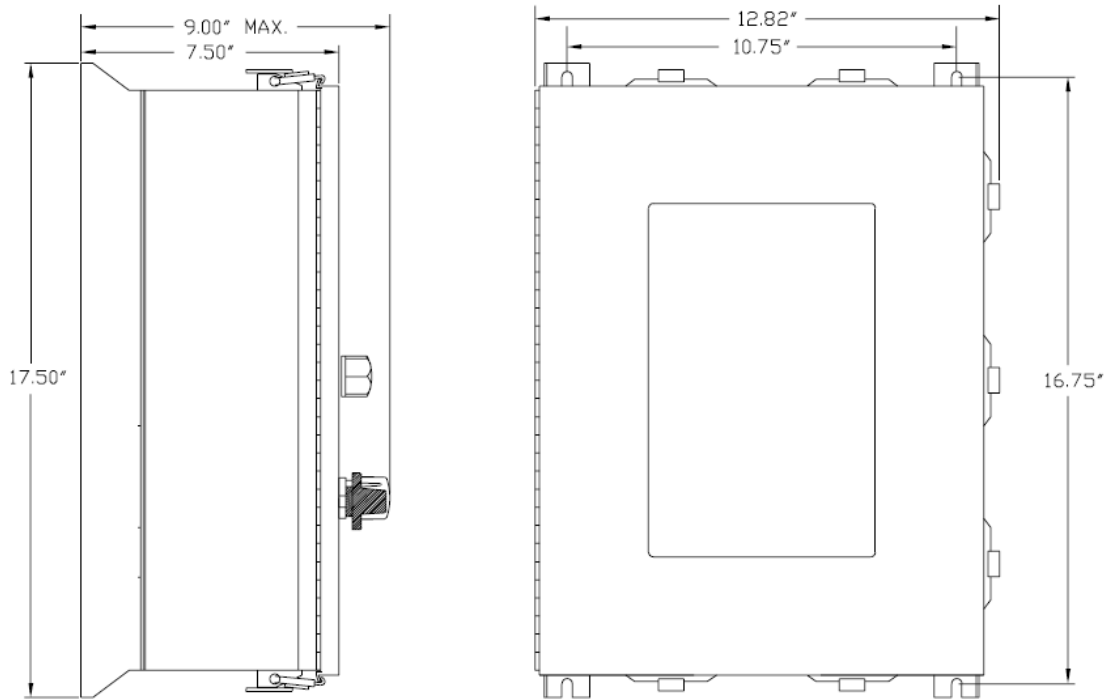
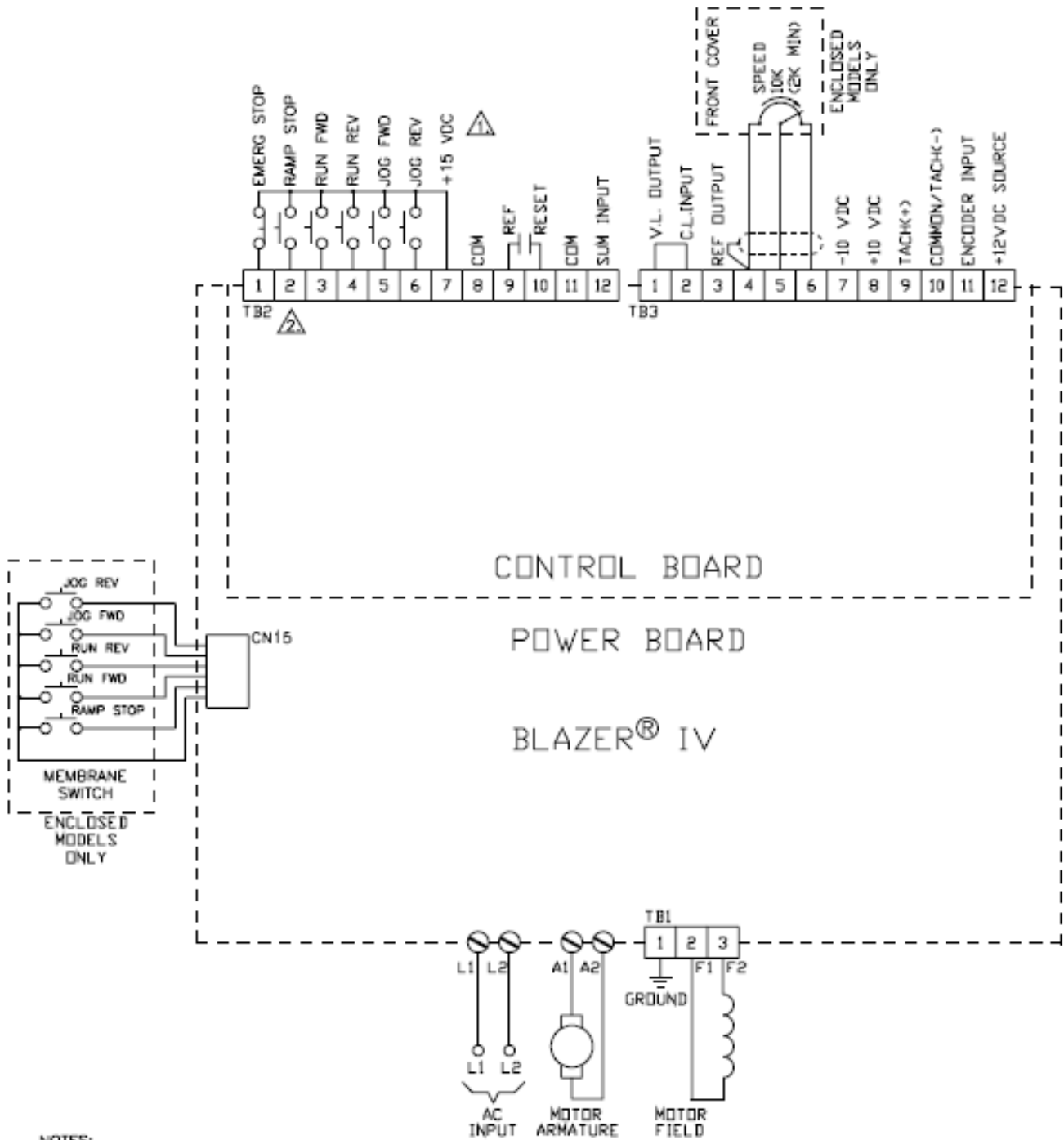

Fig. E.4

Connections

2 HP Models



- NOTES:
- ⚠ NOT REQUIRED FOR ENCLOSED MODELS BUT MAY BE USED FOR AN OPTIONAL REMOTE STATION.
 - ⚠ FOR A NORMALLY OPEN REMOTE SWITCH ON RAMP STOP SET J7 TO NO.

Fig. E.5

Connections

5 HP Models

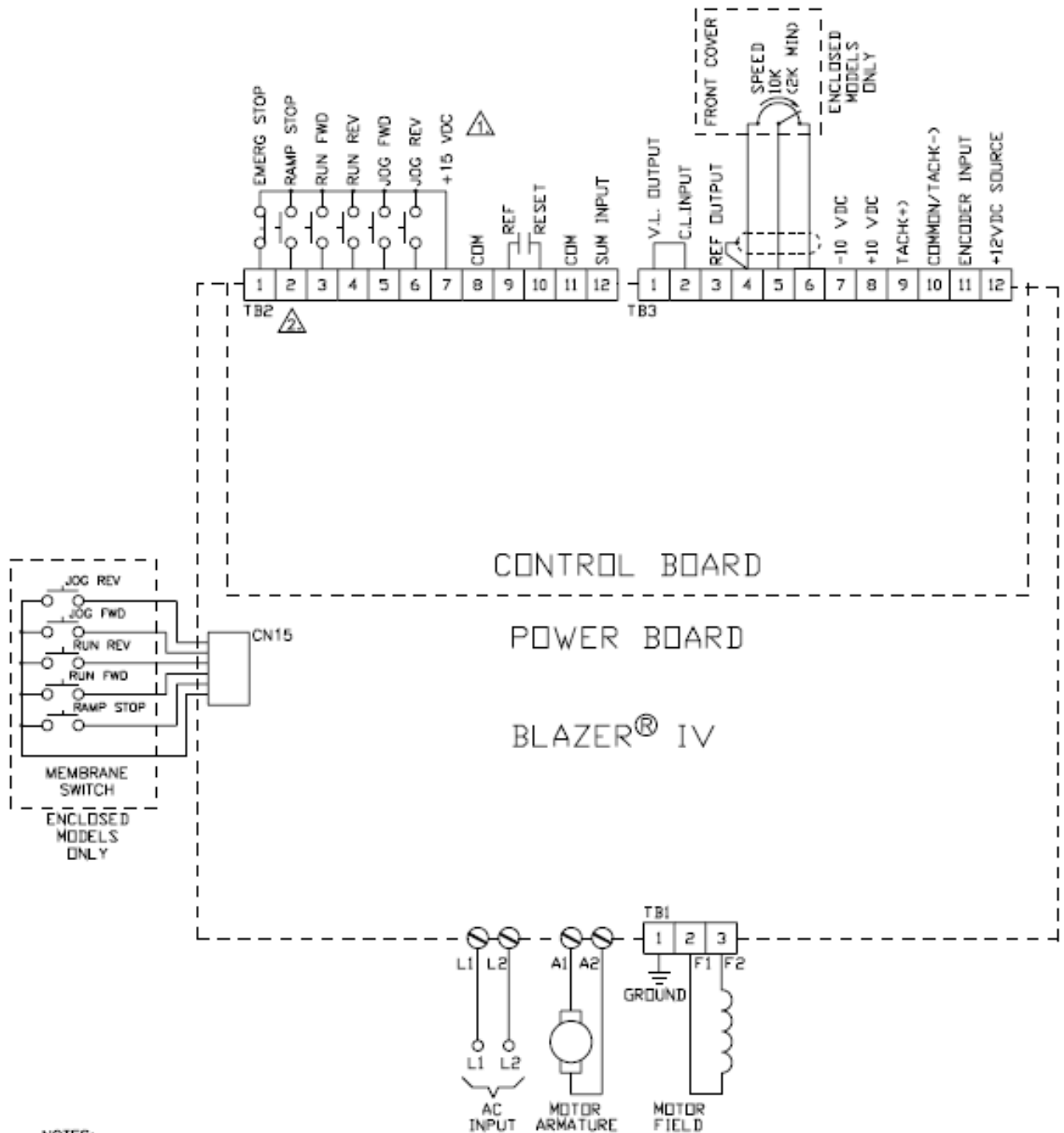

- NOTES:
- ⚠ NOT REQUIRED FOR ENCLOSED MODELS BUT MAY BE USED FOR AN OPTIONAL REMOTE STATION.
 - ⚠ FOR A NORMALLY OPEN REMOTE SWITCH ON RAMP STOP SET J7 TO NO.

Fig. E.6

Blazer IV®
Series ¼ - 5hp Isolated Regen Drives

View or download the complete Blazer IV Instruction Manual (MAN 1008-00) from www.carotron.com .



3204 Rocky River Road Heath Springs, SC 29058
Phone: (803) 286-8614 Fax: (803) 286-6063
Email: saleserv@carotron.com Web: www.carotron.com
FLY1049-0A Issued 03-12-2013