

# DCM100 Drive Circuit Monitor

## General Description

The DCM100-000 Drive Circuit Monitor provides a precision handheld troubleshooting aid for use with the Carotron CHOICE®, BLAZER®, BLAZER®IV and Elite® Series of D.C. motor controls and the Carotron Field Regulator Unit. This unit is battery operated from a single 9 VDC battery and conveniently plugs into the drive to be tested via a 2 foot ribbon cable.

The heart of this instrument is a precision 3-3/4 digit auto-ranging voltmeter integrated circuit. Also supplied is a switching circuit to select between 18 check points on the BLAZER® drives and 20 check points on the CHOICE® drives.

Supplied with each instrument is a padded carrying case to protect the unit in a maintenance environment. Also supplied are detailed pocket size User Guide booklets for each series.

## Standard Features

- Auto-reading voltmeter circuit for more precise circuit voltage readings
- 3-3/4 digit, 0.5"H liquid crystal display for voltage readout
- Alpha characters "A" through "T" to indicate test point selected
- Cursor driven switching circuit to select between 18 check points on the BLAZER® Series and 20 check points on the CHOICE® Series
- Operates from a single 9 VDC battery with approximately 30 hours of continuous operation and LCD Low Battery indication
- Automatic power off circuit shuts down the unit when idle for more than 10 minutes
- Membrane switches for Power On, Power Off, Cursor Up and Cursor Down operation
- 2 foot ribbon cable for connecting the unit to a test drive Padded carrying case with handle and belt loop



DCM100-000

# Dimensions

## DCM100

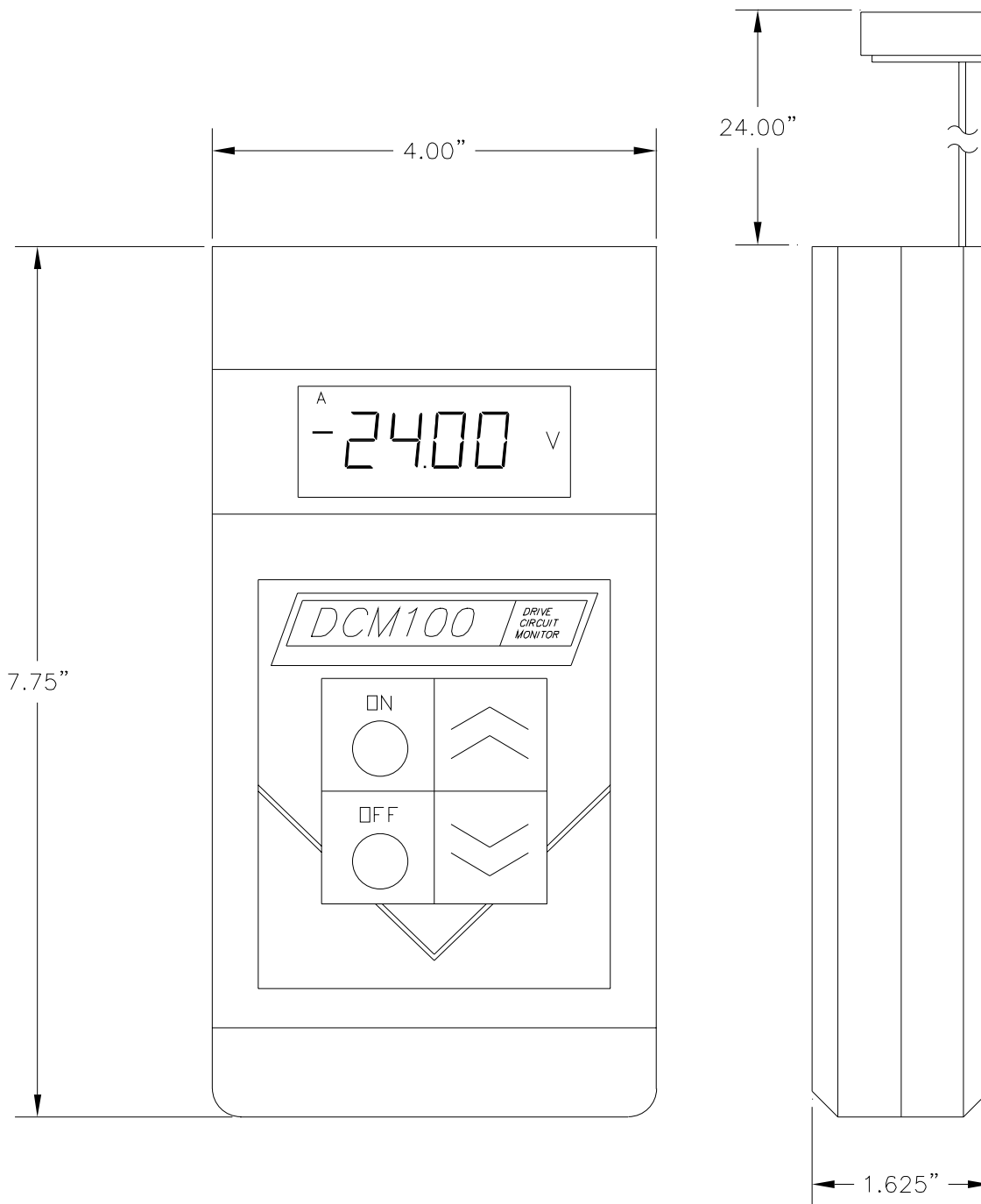

Fig. K.1