

# Signal Isolation Card

**Instruction Manual**  
**Model C10209-000**

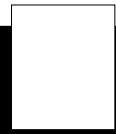



# Table of Contents

<b>1. General Description</b> . . . . .	<b>3</b>
<b>2. Specifications</b> . . . . .	<b>3</b>
<b>3. Description of jumpers and adjustments</b> . . . . .	<b>4</b>
<b>4. Adjustment Procedure</b> . . . . .	<b>4</b>
4.1 Potentiometer Input . . . . .	5
4.2 Voltage Input . . . . .	5
4.3 Current Input . . . . .	5
4.4 Frequency Input . . . . .	6
4.5 Inverted Output Logic . . . . .	6
4.6 Adjusting Output for Low Input . . . . .	6
4.7 Outputs Greater than 12VDC up to 24VDC . . . . .	6
<b>5. Prints</b> . . . . .	<b>7</b>
5.1 C10168 . . . . .	7
5.2 C10209 . . . . .	8
5.3 C11614 . . . . .	9
5.4 D10229 . . . . .	10

# 1 General Description

Model C10209-000 Signal Isolation Card is designed for applications where signal conditioning is required in a single channel, while maintaining electrical isolation between the input and output signals. Designed for a wide variety of input signals, Model C10209-000 can accept the following types of inputs:

- Potentiometer
- D.C. Voltage
- D.C. Current
- Sine or Square Wave Frequency

Each input signal is conditioned by scaling cir-

cuits which can be modified via multi-turn OFFSET, BIAS, and GAIN potentiometer adjustments on the Signal Isolation Card. Terminal strip connections are provided for an external TRIM pot. and an external Summing Input. A single turn TRIM RANGE adjustment is supplied on the Signal Isolation Card to limit the range of the external TRIM pot. The output circuit can be configured to source either a voltage or a current. Typical output ranges are 0 to +10 VDC, 0 to 20 mADC, or 4 to 20 mADC.

# 2 Specifications

## A.C. Input

115/230 VAC  $\pm 10\%$ , 50/60 Hz, 6.8 VA max.

## Isolation Voltage

2000 V PEAK, 1 second or 480 VRMS max.

## Linearity

$\pm 0.5\%$  of 10 VDC span

## Signal Inputs

### • Pot. Input

+ 15 VDC,  $\pm 5\%$  available (50mA max) to source a 2,000 to 10,000 Ohm pot. Use 25 VDC Input Range with external pot.

### • Voltage Input

4 selectable ranges with greater than 1 Meg Ohm input impedance. Max. output is approximately 12 VDC or 24 mADC.

<u>Input Range</u>	<u>Gain Range</u>
0 to 25 VDC	0.25 to 1.25
0 to 50 VDC	0.10 to 0.50
0 to 100 VDC	0.05 to 0.25
0 to 200 VDC	0.025 to 0.125

### • Current Input

3 selectable ranges with impedance as shown below. Maximum output is 12 VDC or 24 mADC. Typical output range with max. input is 5 to 10 VDC or 10 to 20 mADC.

<u>Input Range</u>	<u>Input Impedance</u>
1 to 5 mADC	1000 Ohms
4 to 20 mADC	270 Ohms
10 to 50 mADC	100 Ohms

### • Frequency Input

A sine or square wave input is acceptable with a peak of 1 to 20 V. Input impedance is 100 K Ohms. Maximum input frequency is 2000 Hz. GAIN Range ( $V_{out}/F_{in}$ ) = 0.0028 to 0.014. Minimum frequency to give 10 VDC output is approximately 750 Hz. Maximum output is limited to 12 VDC or 24 mADC.

## Auxiliary Inputs

### • Trim Pot. Input

Allows connection of an external 10,000 Ohm pot. to trim the output. Trim range may be as wide as 0 to 100% or limited to 80 to 100%.

### • Summing Input

This input allows a signal to be summed directly (gain of 1) with the output. Polarity may be inverted by selecting (-) on J7. Isolation is not maintained between the Summing Input and the output.

## Output Types

### • Voltage Output

Selected by position V on Jumper J6. This circuit allows the output to source a voltage level of up to 12 VDC into a minimum resistance of 600 Ohms. If resistance is too low, output linearity may be effected.

### • Current Output

Selected by position I on Jumper J6. This circuit allows the output to source a regulated current of up to 20 mAmps into a maximum resistance of 500 Ohms. Using the BIAS pot., the output can source a 4 to 20 mAmp signal.

# 3 Description of Jumpers, Adjustments

## Jumper J1

Selects between the 3 Current Input Ranges:  
1-5 mA, 4-20 mA, or 10-50 mA.

## Jumper J2

Selects between the 4 Voltage Input Ranges:  
25V, 50V, 100V, or 200V.

## Jumper J3

Selects either the Voltage input circuit or the Current input circuit as the reference source. The unused circuit is disconnected so that it cannot cause interference.

## Jumper J4

Selects either the Frequency circuit or the V/I (Voltage/Current) circuit as the reference source. The unused circuit is disconnected to prevent interference.

## Jumper J5

Selects between 2 output filter networks. Normally J5 is set for FAST to give the fastest response to input changes. Some applications with Frequency as the reference source may require more filtering to reduce output ripple voltages. In these cases, J5 should be put in the SLOW position.

## Jumper J6

Selects the Output Mode between Voltage or Current. Position V on J6 selects the Voltage Mode and the output is sourced from TB2-1 and -2. Position I on J6 selects the Current Mode and the output is sourced from TB2-1 and -3.

## Jumper J7

Selects inverting or non-inverting for the

Summing Input. Position (-) on J7 causes the Summing Input signal to be inverted with respect to the output (example: a positive 5 VDC becomes negative 5 VDC at the output).

Position (+) on J7 causes the Summing Input to remain the same or non-inverted with respect to the output (example: a positive 5 VDC remains positive 5 VDC at the output).

When using the Summing Input to boost the output signal, J7 must be placed in the (-) position. This is because the output from TB2-5 is inverted with respect to the output, and must be inverted again to increase the output signal.

## OFFSET Pot.

Used to null the first stage amplifier section to 0.0 VDC with minimum reference input.

## GAIN Pot.

Used to set the maximum output level with maximum reference input.

## TRIM Pot.

Used to ratio the output of the first amplifier stage from 100% down to a level set by the TRIM RANGE pot.

## TRIM RANGE Pot.

Used to set the minimum level for the TRIM pot. Using a 10K TRIM pot., the trim range can be set as wide as 0 to 100% or as narrow as 80 to 100%.

## BIAS Pot.

Used to set the desired output level with the minimum reference input.

# 4 Adjustment Procedure

**A Note About Shielding**  
All signals should use shielded cable with one end of the shield tied only to the common ter-

minal of the receiving device and the other end insulated.

Here are three examples:

- If a potentiometer is used to provide an input reference to the Signal Isolation Card, the shield should be tied to TB1-7.
- If the output from this card is used as the reference signal for a motor control, then the shield should be connected to the common terminal of the motor control.
- If a summing signal is used on the output of the card, then the shield should be connected to TB2-2 (also called the voltage return).

#### Adjustment Procedure

Select the type of input signal desired and use the appropriate procedure listed below. In each case, make the following selections prior to starting the adjustment procedure.

- Select the type of output desired using Jumper J6. If a Voltage output is desired, select V on J6 and use output terminals TB2-1 (OUTPUT) and TB2-2 (VOLTAGE RETURN). If a Current output is desired, select I on J6 and use output terminals TB2-1 (OUTPUT) and TB2-3 (CURRENT RETURN).
- If a Summing Input is used, make sure this input is at zero for the following calibration adjustments.
- If a TRIM pot. is used, turn it to the full clockwise position. If a limited trim range is desired, preset the TRIM RANGE pot. per the following to approximate the range desired.

TRIM RANGE Pot Setting	10 K TRIM Pot. Adjustment Range
0% Clockwise	0 to 100%
25% Clockwise	55 to 100%
50% Clockwise	71 to 100%
100% Clockwise	83 to 100%

If a TRIM pot. is not used, jumper TB2-5 to -6.

## 4.1 Potentiometer Input

- Connect the potentiometer per drawing D10229. Select 25V on Jumper J2, Voltage on J3, V/I on J4, and Fast on J5.
- Apply power to the Signal Isolation Card. Turn the input pot. full counter clockwise. Turn the GAIN pot. full clockwise (approximately 20 turns). Adjust the OFFSET pot. for 0.0 VDC between TB2-5 and TB2-2. Turn the GAIN pot. full counter clockwise (approximately 20 turns).
- Adjust the BIAS pot. for the minimum output level desired with minimum reference input. Turn the input pot. full clockwise. Adjust the GAIN pot. for the maximum desired output.
- The unit is now calibrated for operation. The

output level relative to the input signal may now be trimmed by the TRIM pot. or an external signal may be summed using the Summing Input at TB2-4.

## 4.2 Voltage Input

- Connect the voltage reference input per drawing D10229. Select Voltage on Jumper J3, V/I on J4, and Fast on J5.
- Select the proper voltage input range on Jumper J2 by using the following procedure:
  - Determine the maximum input ( $V_{in}$ ).
  - Select the lowest input range which is greater than or equal to your determined  $V_{in}$ .
  - Refer to Section 2, Signal Inputs:Voltage Input, for the GAIN RANGE ( $V_{out}/V_{in}$ ) for each input range. Multiply the values shown in the GAIN RANGE times your  $V_{in}$  to determine the nominal adjustment range of voltage output. If the product of the two values exceeds 12 VDC, the output section will saturate at high GAIN pot. settings and the voltage will be limited to approximately 12 VDC.

Example:

- Desired  $V_{in}$  = 12.25 Volts (7 VDC/1000 RPM @ 1750 RPM).
- Select the 25V range on Jumper J2. (25V > 12.25V).
- $V_{out}$  (minimum) =  $.25 \times 12.25V = 3.1$  VDC  
 $V_{out}$  (maximum) =  $1.25 \times 12.25V = 15.3$  VDC (not valid, 12 VDC is max.)  
Usable GAIN adjustment range is 3.1 to 12 VDC output with 12.25 VDC input.
- Select the proper input range on J2 as determined above. With the reference input at minimum, apply power to the Signal Isolation Card. Turn the GAIN pot. full clockwise (approximately 20 turns). Adjust the OFFSET pot. for 0.0 VDC between TB2-5 and TB2-2. Turn the GAIN pot. full counter clockwise (approximately 20 turns).
- Measure the voltage between TB2-1 and TB2-2. Adjust the BIAS pot for the minimum output level desired with minimum reference input. Apply full reference input voltage. Adjust the GAIN pot for the maximum desired output.
- The unit is now calibrated for operation. The output level relative to the input signal may now be trimmed by the TRIM pot. or an external signal may be summed using the Summing Input at TB2-4.

## 4.3 Current Input

- Connect the current input per drawing D10229. Select 1-5 mA, 4-20 mA, or 10-50 mA input range using Jumper J1. Select Current on J3, V/I on J4, and Fast on J5.
- Apply power to the Signal Isolation Card.

Apply the minimum current reference input. Turn the GAIN pot. full clockwise (approximately 20 turns). Adjust the OFFSET pot. for 0.0 VDC between TB2-5 and TB2-2. Turn the GAIN pot. full counter clockwise (approximately 20 turns).

- Adjust the BIAS pot. for the minimum output level desired with minimum reference input. Apply the maximum current reference. Adjust the GAIN pot. for the maximum desired output.
- The unit is now calibrated for operation. The output level relative to the input signal may now be trimmed by the TRIM pot. or an external signal may be summed using the Summing Input at TB2-4.

## 4.4 Frequency Input

- Connect the frequency input per drawing D10229. Select FREQ on Jumper J4 and Fast on J5.
- With minimum reference input frequency, apply power to the Signal Isolation Card. Turn the GAIN pot. full clockwise (approximately 20 turns). Adjust the OFFSET pot. for 0.0 VDC between TB2-5 and TB2-2. Turn the GAIN pot. full counter clockwise (approximately 20 turns).
- Adjust the BIAS pot. for the minimum output level desired with minimum reference input. Apply full reference frequency input. Adjust the GAIN pot. for the maximum desired output.
- The unit is now calibrated for operation. The output level relative to the input signal may now be trimmed by the TRIM pot. or an external signal may be summed using the Summing Input at TB2-4.

## 4.5 Inverted Output Logic

- The card can be set up so that the output can be inversely proportional to the input. Connect input section per the desired method above. Refer to drawing D10220, Inverted Output Logic Section, and connect the motor control and optional TRIM pot. accordingly. Place J6 on V and J7 on (+).

- Apply power to the Signal Isolation Card. Apply the minimum input reference. Turn the GAIN pot. full clockwise (approximately 20 turns). Adjust the offset pot. for 0.0 VDC between TB2-5 and TB2-2. Turn the GAIN pot. full counter clockwise (approximately 20 turns).
- Adjust the BIAS pot. for the maximum output level needed with minimum reference input. Adjust the input signal to maximum. Adjust the GAIN pot. for the minimum output.
- The unit is now calibrated for operation. The output level relative to the input signal may be trimmed by the TRIM pot. when connected as shown.

## 4.6 Adjusting Output for Low Input

- One method of achieving full output from a 5 VDC input is to use the current input and remove J1. The current input is scaled for the 5 volt range, and removing the J1 jumper removes the burden resistors from the input network.
- Alternately, for input range maximums in the 4 to 5 volt, or 2 to 2.5 mA range, the summing input can also be used to double the output range. This is done by jumping TB2-6 to TB2-4, setting J7 to (-), setting J6 to the desired output, and then setting up the card by the instructions appropriate to the signal input type.
- Remember, the output limit from common to TB2-1 is still 12 VDC or 20mADC.

## 4.7 Outputs Greater Than 12VDC up to 24 VDC

- When the BIAS and OFFSET pots are both set at 0, the voltage at TB2-5 is opposite in polarity, but equal in magnitude to TB2-1. This can be used to achieve up to 24 VDC output signal as long as the load is no more than 5 mA. Refer to drawing D10229, 24 VDC OUTPUT. This is achieved by making TB2-6 the common of the motor controller and using TB2-1 as the reference.

# 5 Prints

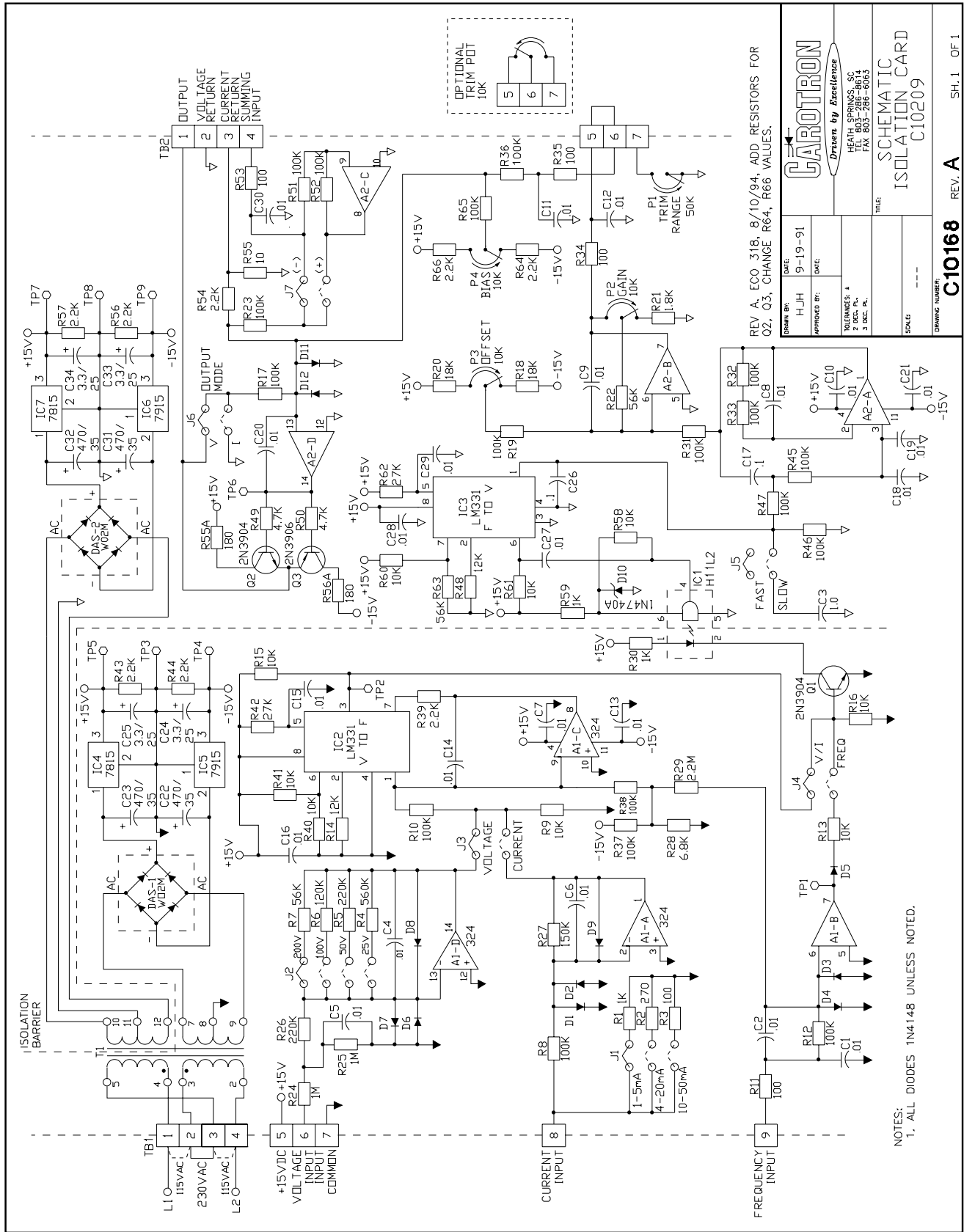

DATE: 9-19-91  
 DRAWN BY: HJH  
 APPROVED BY: [Signature]  
 TOLERANCES: \* 2 DEC. PL.  
 3 DEC. PL.  
 SCALE: ---  
 DRAWING NUMBER: **C10168** REV. A SH. 1 OF 1

REV. A, ECO 318, 8/10/94. ADD RESISTORS FOR Q2, Q3, CHANGE R64, R66 VALUES.

**CAROTRON**  
*Driven by Excellence*  
 HEATH SPRINGS, SC  
 TEL 803-286-8614  
 FAX 803-286-8063

TITLE: SCHEMATIC CARD  
 C10209

NOTES:  
 1. ALL DIODES 1N4148 UNLESS NOTED.

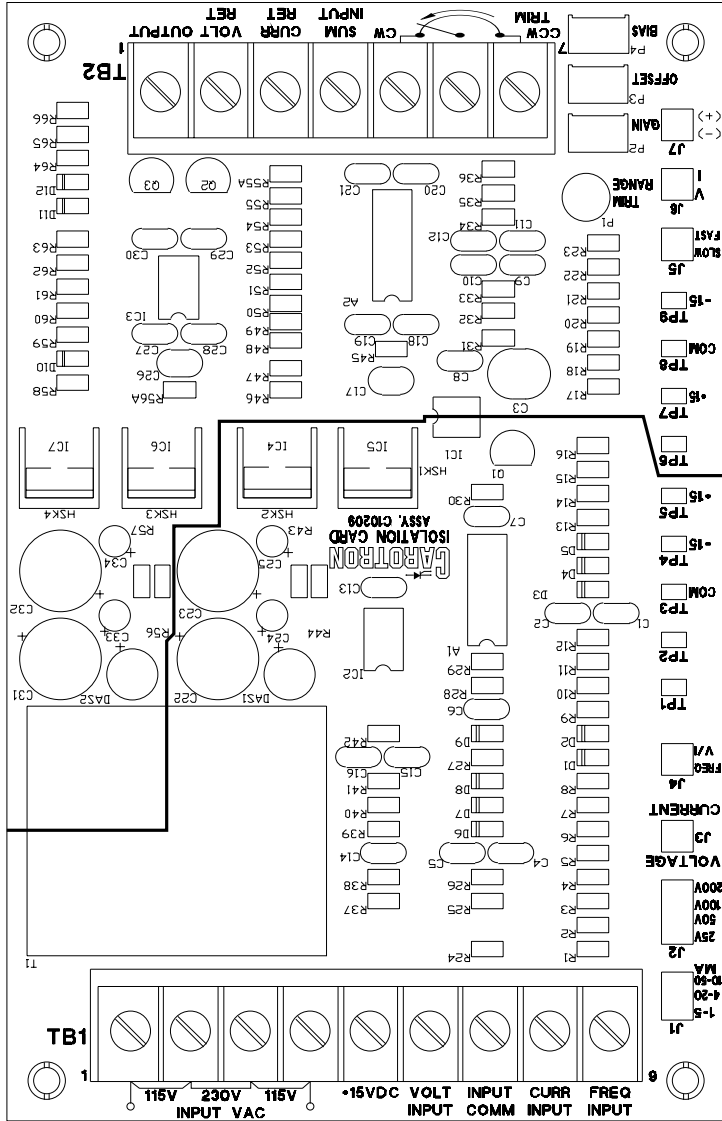

REV. B, 8/30/94, ECD 318  
 REV. A, 8/26/87, ECD 19

DATE: 8/3/87  
 DRAWN BY: HJH  
 APPROVED BY: [Signature]

HEALTH SPRINGS, SC  
 2 DEC. PL.  
 3 DEC. PL.  
 4 DEC. PL.



HEALTH SPRINGS, SC  
 2 DEC. PL.  
 3 DEC. PL.  
 4 DEC. PL.

ISOLATION CARD  
 ASSEMBLY  
 C10209

REV. B  
 SH. 1 OF 1

REV. B  
 SH. 1 OF 1

REV. B  
 SH. 1 OF 1

REV. B  
 SH. 1 OF 1



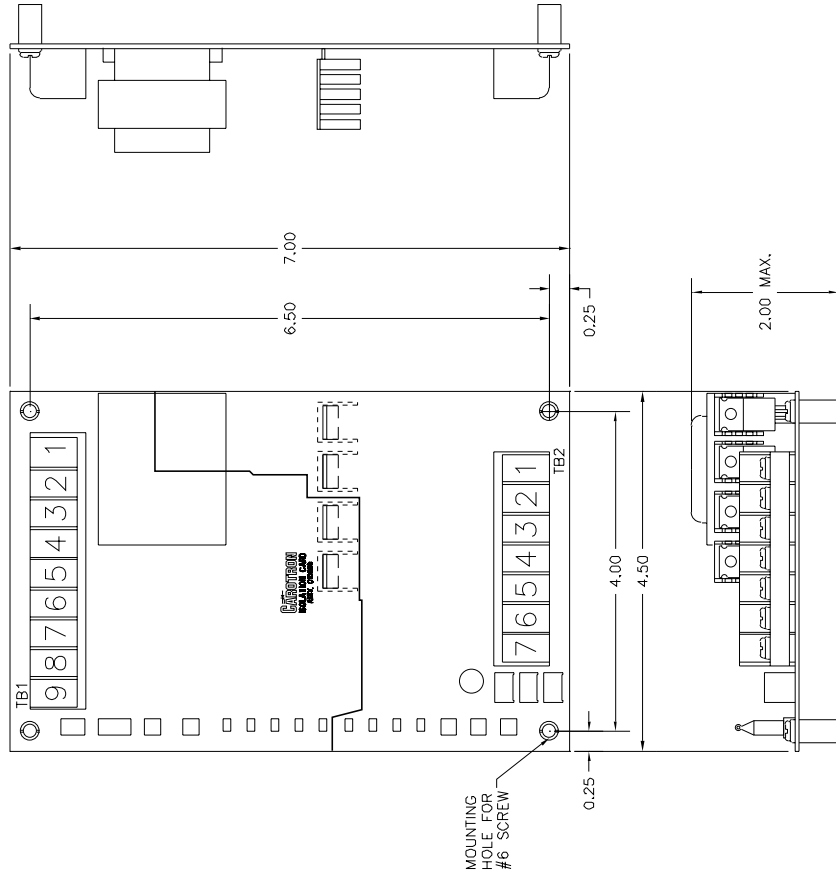

DRAWN BY:	DATE:
UBJ	2/22/95
APPROVED BY:	DATE:
TOLERANCES:	1. FRACTIONS = 1/16
	2. DEC. PL. = 80P
	3. DEC. PL. = 20P
SCALE:	
<b>CAROTRON</b> <i>Driven by Excellence</i> HEATH SPONGES, SC TEL. 803-286-8674 FAX 803-286-6063	
TITLE: DIMENSION DRAWING	
SIGNAL ISOLATION CARD	
MODEL C10209-000	
DRAWING NUMBER:	REV.
<b>C11614</b>	1
	SH. 1 OF 1

POTENTIOMETER INPUT

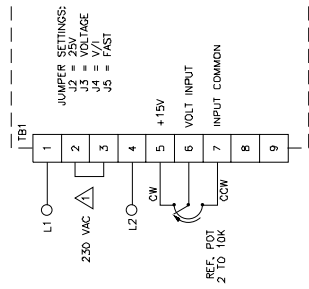

CURRENT INPUT

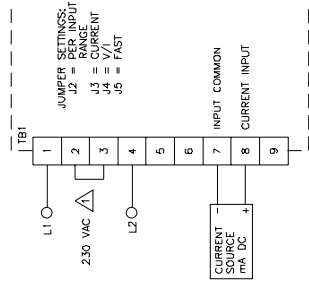

VOLTAGE OUTPUT

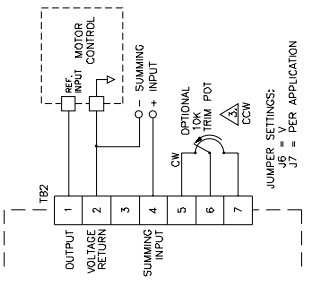

INVERTED OUTPUT LOGIC  
 (INCREASING INPUT CAUSES DECREASING OUTPUT)

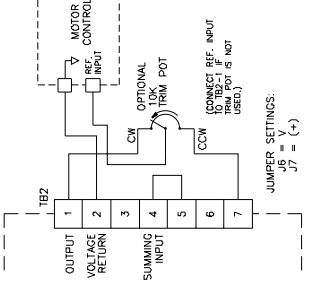

VOLTAGE INPUT

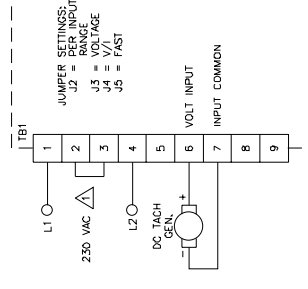

FREQUENCY INPUT

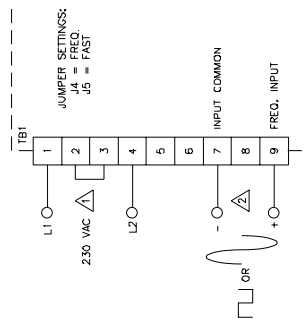

CURRENT OUTPUT

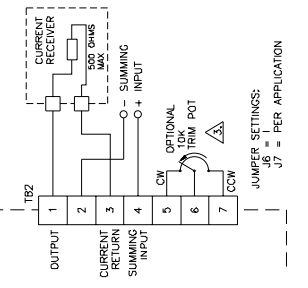

24 VDC OUTPUT

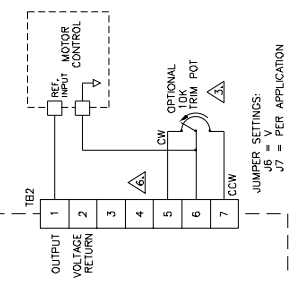

GENERAL CONNECTIONS

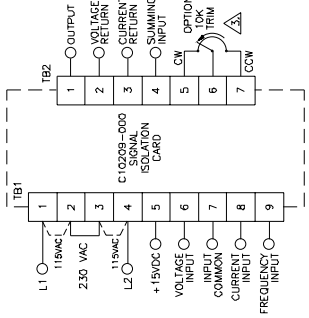

- NOTES:
- CONNECTION SHOWN FOR 230VAC. FOR 115 VAC TO 120 VAC, REMOVE JUMPER TB1-2 TO 3, ADD JUMPER TB1-1 TO 2.
  - SELECTION OF SLOW OR FAST RANGE MAY REQUIRE JUMPER TB2-5 TO 6 IF TRIM POT IS NOT USED.
  - REF. INPUT SIGNALS SHOULD USE SHIELDED CABLE WITH THE SHIELD TIED TO CIRCUIT COMMON AT THE SIGNAL RECEIVING END ONLY.
  - FOR CURRENT INPUT WITH THIS CONFIGURATION.

REV. A: 2/20/95 ADDED INVERTED LOGIC & 24V DRAWINGS. MOVED DIMENSION DRAWING TO C11614.

UBJ zprovis  
 APPROVED BY: [Signature]  
 DATE: [Date]  
 TELEPHONE: [Number]  
 FAX: [Number]  
 SCALE: [Scale]

Carotron  
 DIVISION OF ZEPHYRUS  
 CONNECTION & DIMENSION DIAGRAM FOR C10209-000, SIGNAL ISOLATION CARD

REV. A SH. 1 OF 1

# Standard Terms & Conditions of Sale

## 1. General

The Standard Terms and Conditions of Sale of Carotron, Inc. (hereinafter called "Company") are set forth as follows in order to give the Company and the Purchaser a clear understanding thereof. No additional or different terms and conditions of sale by the Company shall be binding upon the Company unless they are expressly consented to by the Company in writing. The acceptance by the Company of any order of the Purchaser is expressly conditioned upon the Purchaser's agreement to said Standard Terms and Conditions. The acceptance or acknowledgement, written, oral, by conduct or otherwise, by the Company of the Purchaser's order shall not constitute written consent by the Company to addition to or change in said Standard Terms and Conditions.

## 2. Prices

Prices, discounts, allowances, services and commissions are subject to change without notice. Prices shown on any Company published price list and other published literature issued by the Company are not offers to sell and are subject to express confirmation by written quotation and acknowledgement. All orders of the Purchaser are subject to acceptance, which shall not be effective unless made in writing by an authorized Company representative at its office in Heath Springs, S.C. The Company may refuse to accept any order for any reason whatsoever without incurring any liability to the Purchaser. The Company reserves the right to correct clerical and stenographic errors at any time.

## 3. Shipping dates

Quotation of a shipping date by the Company is based on conditions at the date upon which the quotation is made. Any such shipping date is subject to change occasioned by agreements entered into previous to the Company's acceptance of the Purchaser's order, governmental priorities, strikes, riots, fires, the elements, explosion, war, embargoes, epidemics, quarantines, acts of God, labor troubles, delays of vendors or of transportation, inability to obtain raw materials, containers or transportation or manufacturing facilities or any other cause beyond the reasonable control of the Company. In no event shall the Company be liable for consequential damages for failure to meet any shipping date resulting from any of the above causes or any other cause.

In the event of any delay in the Purchaser's accepting shipment of products or parts in accordance with scheduled shipping dates, which delay has been requested by the Purchaser, or any such delay which has been caused by lack of shipping instructions, the Company shall store all products and parts involved at the Purchaser's risk and expense and shall invoice the Purchaser for the full contract price of such products and parts on the date scheduled for shipment or on the date on which the same is ready for delivery, whichever occurs later.

## 4. Warranty

The Company warrants to the Purchaser that products manufactured or parts repaired by the Company, will be free, under normal use and maintenance, from defects in material and workmanship for a period of one (1) year after the shipment date from the Company's factory to the Purchaser. The Company makes no warranty concerning products manufactured by other parties.

As the Purchaser's sole and exclusive remedy under said warranty in regard to such products and parts, including but not limited to remedy for consequential damages, the Company will at its option, repair or replace without charge any product manufactured or part repaired by it, which is found to the Company's satisfaction to be so defective; provided, however, that (a) the product or part involved is returned to the Company at the location designated by the Company, transportation charges prepaid by the Purchaser; or (b) at the Company's option the product or part will be repaired or replaced in the Purchaser's plant; and also provided that (c) the Company is notified of the defect within one (1) year after the shipment date from the Company's factory of the product or part so involved.

The Company warrants to the Purchaser that any system engineered by it and started up under the supervision of an authorized Company representative will, if properly installed, operated and maintained, perform in compliance with such system's written specifications for a period of one (1) year from the date of shipment of such system.

As the Purchaser's sole and exclusive remedy under said warrant in regard to such systems, including but not limited to remedy for consequential damages, the Company will, at its option, cause, without charges any such system to so perform, which system is found to

the Company's satisfaction to have failed to so perform, or refund to the Purchaser the purchase price paid by the Purchaser to the Company in regard thereto; provided, however, that (a) Company and its representatives are permitted to inspect and work upon the system involved during reasonable hours, and (b) the Company is notified of the failure within one (1) year after date of shipment of the system so involved.

The warranties hereunder of the Company specifically exclude and do not apply to the following:

a. Products and parts damaged or abused in shipment without fault of the Company.

b. Defects and failures due to operation, either intentional or otherwise, (1) above or beyond rated capacities, (2) in connection with equipment not recommended by the Company, or (3) in an otherwise improper manner.

c. Defects and failures due to misapplication, abuse, improper installation or abnormal conditions of temperature, humidity, abrasives, dirt or corrosive matter.

d. Products, parts and systems which have been in any way tampered with or altered by any party other than an authorized Company representative.

e. Products, parts and systems designed by the Purchaser.

f. Any party other than the Purchaser.

The Company makes no other warranties or representation, expressed or implied, of merchantability and of fitness for a particular purpose, in regard to products manufactured, parts repaired and systems engineered by it.

## 5. Terms of payment

Standard terms of payment are net thirty (30) days from date of the Company invoice. For invoice purposed, delivery shall be deemed to be complete at the time the products, parts and systems are shipped from the Company and shall not be conditioned upon the start up thereof. Amounts past due are subject to a service charge of 1.5% per month or fraction thereof.

## 6. Order cancellation

Any cancellation by the Purchaser of any order or contract between the Company and the Purchaser must be made in writing and receive written approval of an authorized Company representative at its office in Heath Springs, S.C. In the event of any cancellation of an order by either party, the Purchaser shall pay to the Company the reasonable costs, expenses, damages and loss of profit of the Company incurred there by, including but not limited to engineering expenses and expenses caused by commitments to the suppliers of the Company's subcontractors, as determined by the Company.

## 7. Changes

The Purchaser may, from time to time, but only with the written consent of an authorized Company representative, make a change in specifications to products, parts or systems covered by a purchase order accepted by the Company. In the event of any such changes, the Company shall be entitled to revise its price and delivery schedule under such order.

## 8. Returned material

If the Purchaser desires to return any product or part, written authorization thereof must first be obtained from the Company which will advise the Purchaser of the credit to be allowed and restocking charges to be paid in regard to such return. No product or part shall be returned to the Company without a "RETURN TAG" attached thereon which has been issued by the Company.

## 9. Packing

Published prices and quotations include the Company's standard packing for domestic shipment. Additional expenses for special packing or overseas shipments shall be paid by the Purchaser. If the Purchaser does not specify packing or accepts parts unpacked, no allowance will be made to the Purchaser in lieu of packing.

## 10. Standard transportation policy

Unless expressly provided in writing to the contrary, products, parts and systems are sold f.o.b. first point of shipment. Partial shipments shall be permitted, and the Company may invoice each shipment separately. Claims for non-delivery of products, parts and systems, and for damages thereto must be filed with the carrier by the Purchaser. The Company's responsibility therefor shall cease when the carrier signs for and accepts the shipment.



3204 Rocky River Road  
Heath Springs, SC 29058  
Phone: (803) 286-8614  
FAX: (803) 286-6063

**MAN 1014-0E**  
**Issued 11-16-11**