

Signal Isolation Module

**Instruction Manual
SIM200-000**

**CAROTRON**

Driven by Excellence

D.C. DRIVES, A.C. INVERTERS,
SOLID STATE STARTERS, SYSTEM INTERFACE
CIRCUITS AND ENGINEERED SYSTEMS

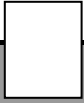

Table of Contents

1. General Description.....	3
2. Specifications	3
2.1 Electrical	3
2.2 Physical	4
3. Installation	4
3.1 Wiring Guidelines	4
3.2 Signal Connections.....	5
4. Description of Jumpers & Adjustments.....	6
5. Adjustment Procedure	6
5.1 Select Output Type	6
5.2 Potentiometer Input	6
5.3 Voltage Input.....	7
5.4 Current Input.....	7
5.5 Trim Range	7
5.6 Outputs Greater Than 12VDC up to 24VDC.....	7
6. Prints	8
C13661 SIM200-000 Block Diagram	8
C13657 SIM200-000 Assembly	9
C13660 SIM200-000 Connections.....	10
7. Standard Terms & Conditions of Sale	11
List of Tables	
Table 1	3
List of Figures	
Figure 1: Physical Dimensions	4
Figure 2: General Connections.....	5

1

General Description

Model SIM200-000 Signal Isolation Module is designed for applications where signal conditioning is required in a single channel, while maintaining electrical isolation between the input and output signals. Designed for a wide variety of input signals, the SIM200-000 Can accept the following types of inputs:

- Potentiometer
- D.C. Voltage
- D.C. Current

Each input signal is conditioned by scaling circuits which can be modified via multi-turn OFFSET, BIAS, and GAIN potentiometer adjustments. Terminal strip connections are provided for an optional external TRIM pot. A multi-turn TRIM RANGE adjustment is also supplied to limit the range of the external TRIM pot. The output circuit can be configured to source either a voltage or current. Typical output ranges are 0 to ± 10 VDC, 0 to 20 mADC, or 4 to 20 mADC.

2

Specifications

2.1 Electrical

D.C. Power Input

24 VDC $\pm 10\%$, 400mA max.

Isolation Voltage

500V (DC or AC Peak)

Linearity

$\pm 0.5\%$ of 10 VDC span

Signal Inputs

- **Pot Input**
+15 VDC, $\pm 5\%$ available to source a 2000 to 10,000 Ohm pot. Use 25 VDC Input Range with external pot.
- **Voltage Input**
4 selectable ranges (via J1) with greater than 1 meg Ohm input impedance.

J1 Input Range	Gain Range
± 25 VDC	0.15 to 2
± 50 VDC	0.06 to 0.82
± 100 VDC	0.04 to 0.45
± 200 VDC	0.01 to 0.20

Table 1

- **Current Input**
Single input range (max ± 20 mA) with

250 ohm impedance. Maximum output is ± 12 VDC or ± 24 mA.

- **Trim Potentiometer Input**
Allows connection of an external 10,000 Ohm pot. to trim the output. Trim range may be as wide as 0 to 100% or limited to 80 to 100%.

Signal Outputs

- **Voltage Output**
Selected by position V on J2. This circuit allows the output to source a voltage level of up to ± 12 VDC into a minimum resistance of 600 Ohms. If resistance is too low, output linearity may be affected.
- **Current Output**
Selected by position I on J2. This circuit allows the output to source a regulated current of up to ± 20 mA into a maximum resistance of 500 Ohms. Using the BIAS pot, the output can source a 4 to 20mA signal.

Temperature Range

- Chassis: 0-55°C

2.2 Physical

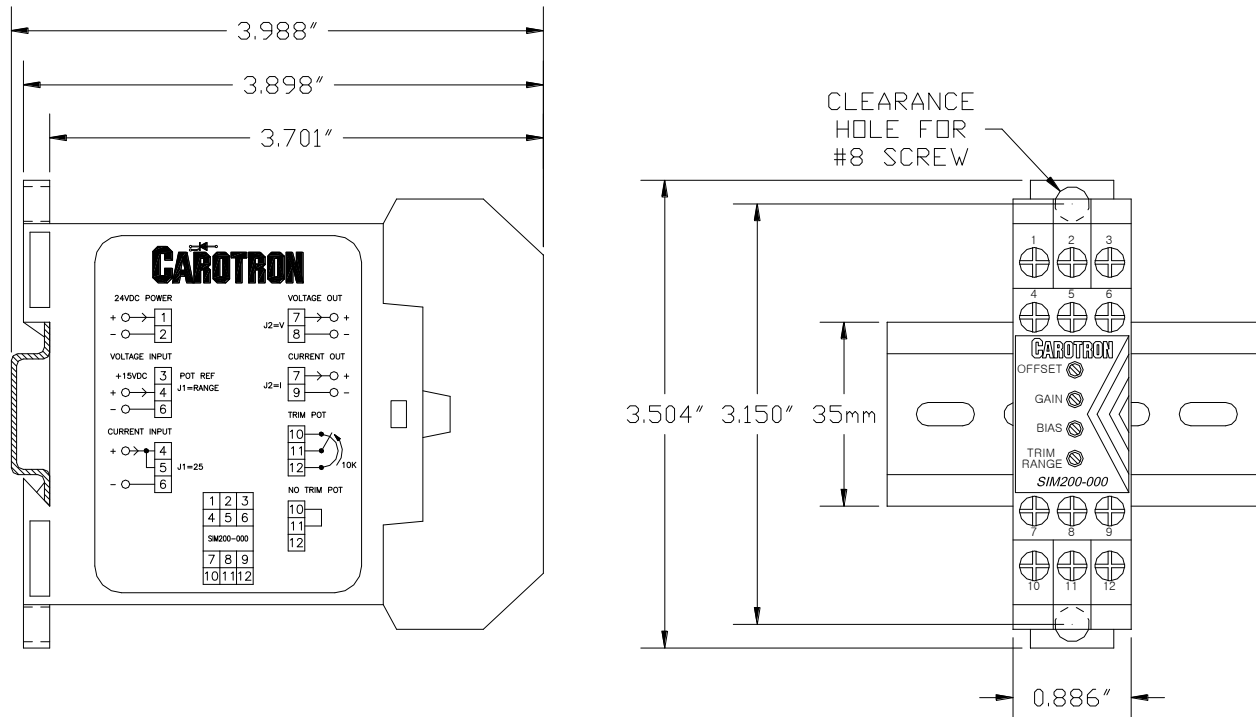

Figure 1: Physical Dimensions

3

Installation

3.1 Wiring Guidelines

To prevent electrical interference and to minimize start-up problems, adhere to the following guidelines:

Use fully insulated and shielded cable for all signal wiring. The shield should be connected to circuit common at one end only. The other end of the shield should be clipped and insulated to prevent the possibility of accidental grounding.

Here are two examples:

- If a potentiometer is used to provide an input reference to the Signal Isolation Module, the shield should be tied to terminal 6.
- If the output from this card is used as the reference signal for a motor control, then the shield should be connected to the common terminal of the motor control.

Signal level wiring such as listed above should be routed separately from high level wiring such as armature, field, operator control and relay control wiring. When these two types of wire must cross, they should cross at right angles to each other.

Any relay, contactor, starter, solenoid or other electro-mechanical device located in close proximity to or on the same line supply as the SIM200-000 should have a transient

suppression device such as an MOV or R-C snubber connected in parallel with its coil. The suppressor should have short leads and be connected as close to the coil as possible.

3.2 Signal Connections

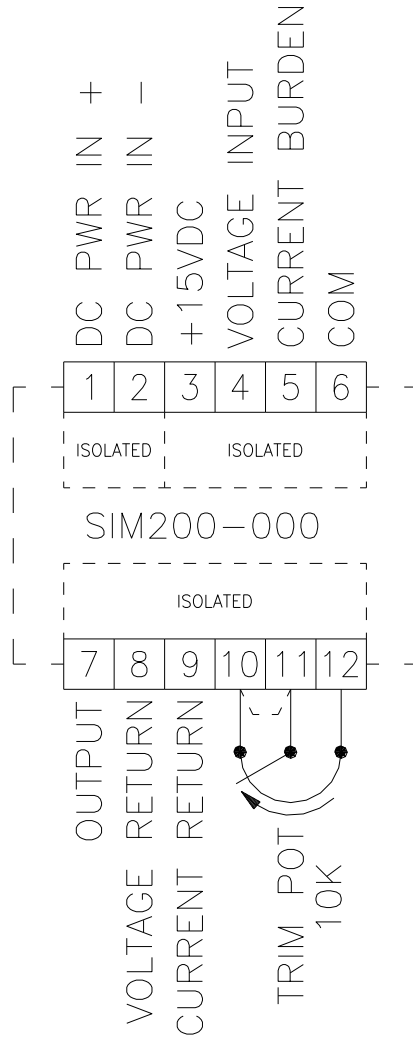

Figure 2: General Connections

4

Description of Jumpers & Adjustments

Jumpers are accessible by removing the cover assembly from the base. Squeeze the enclosure top on both sides and pull up to remove the base.

Jumper J1

Selects between the 4 Voltage Input Ranges: $\pm 25V$, $\pm 50V$, $\pm 100V$, or $\pm 200V$.

Jumper J2

Selects the Output Mode between Voltage or Current. Position V on J2 selects the Voltage Mode and the output is sourced from terminals 7 & 8. Position I on J2 selects the Current Mode and the output is sourced on terminals 7 & 9.

OFFSET Potentiometer

Used to null the first stage amplifier section to 0.0 VDC with minimum reference input.

GAIN Potentiometer

Used to set the maximum input level with maximum reference input.

BIAS Potentiometer

Used to set the desired output level with the minimum reference input.

TRIM RANGE Potentiometer

Used to set the range of the external trim potentiometer.

5

Adjustment Procedure

5.1 Select Output Type

- Select the type of output desired using Jumper J2. If a Voltage output is desired, select V on J2 and use output terminals 7 (OUTPUT) and 8 (VOLTAGE RETURN). If a Current output is desired, select I on J2 and use output terminals 7 (OUTPUT) and 9 (CURRENT RETURN).
- **If a TRIM potentiometer is not used, jumper terminals 10 to 11.** Otherwise, turn the external trim potentiometer to the full clockwise position.
- Proceed to section 5.2 if using a potentiometer input, 5.3 for a voltage input, or 5.4 for a current input.

5.2 Potentiometer Input

- Select 25V on Jumper J1. Connect the potentiometer per drawing C13660.
- Apply power to the Signal Isolation Module. Turn the input potentiometer fully counter-clockwise. Turn the GAIN potentiometer fully clockwise (approximately 20 turns). Adjust the OFFSET potentiometer for 0.0 VDC between terminals 10 and 8. Turn the GAIN potentiometer fully counter clockwise (approximately 20 turns).
- Adjust the BIAS potentiometer for the minimum output level desired (at terminal 7) with minimum reference input. Turn the input potentiometer full clockwise. Adjust the

GAIN potentiometer for the maximum desired output (at terminal 7).

- The unit is now calibrated for operation. Refer to Section 5.5 for optional Trim Range adjustment.

5.3 Voltage Input

- Select the proper voltage input range on Jumper J1 by using the following procedure:
 - a) Determine the maximum input (V_{in}).
 - b) Select the lowest input range which is greater than or equal to your determined V_{in} .
- Connect the voltage reference input per drawing C13660.
- With the reference input at minimum, apply power to the Signal Isolation Module. Turn the GAIN potentiometer fully clockwise (approximately 20 turns). Adjust the OFFSET potentiometer for 0.0 VDC between terminals 10 and 8. Turn the GAIN potentiometer fully counter clockwise (approximately 20 turns). Adjust the BIAS potentiometer for the minimum output level desired (at terminal 7) with minimum reference input. Apply full reference input voltage. Adjust the GAIN potentiometer for the maximum desired output (at terminal 7).
- The unit is now calibrated for operation. Refer to Section 5.5 for optional Trim Range adjustment.

5.4 Current Input

- Select the 25V range on Jumper J1. Wire a jumper from terminal 4 to 5. Connect the current input per drawing C13660.
- Apply Power to the Signal Isolation Module. Apply the minimum current reference input. Turn the Gain potentiometer fully clockwise (approximately 20 turns). Adjust the OFFSET potentiometer for 0.0 VDC between terminals 10 and 8. Turn the GAIN potentiometer fully counter clockwise (approximately 20 turns).
- Adjust the BIAS potentiometer for the minimum output level desired (at terminal 7) with minimum reference input. Apply the maximum current reference. Adjust the GAIN potentiometer for maximum desired output (at terminal 7).
- The unit is now calibrated for operation. Refer to Section 5.5 for optional Trim Range adjustment.

5.5 Trim Range

If desired, the output level relative to the input signal may now be trimmed by an optional external 10K TRIM potentiometer. The Trim Range adjustment can be used to limit the range of the external trim potentiometer. A Trim Range setting of fully counter-clockwise gives the external trim potentiometer a full range of 0 to 100%. A Trim Range setting of fully clockwise gives an external 10K trim potentiometer a range of approximately 80 to 100%. Note that the value of the external trim potentiometer will have an affect on the range of the internal Trim Range potentiometer. If for example an external trim potentiometer of 50K is used, the minimum allowable external trim level will be approximately 40 to 100% (instead of the 80 to 100% with a 10K potentiometer).

5.6 Outputs Greater Than 12VDC up to 24VDC

When the BIAS and OFFSET potentiometers are both set at 0, the voltage at terminal 10 is opposite in polarity, but equal in magnitude to terminal 7. This can be used to achieve up to 24 VDC output signal as long as the load is no more than 5 mA. Refer to drawing C13660, 24 VDC OUTPUT. This is achieved by using terminal 11 as the common (instead of terminal 8) and using terminal 7 as the output.

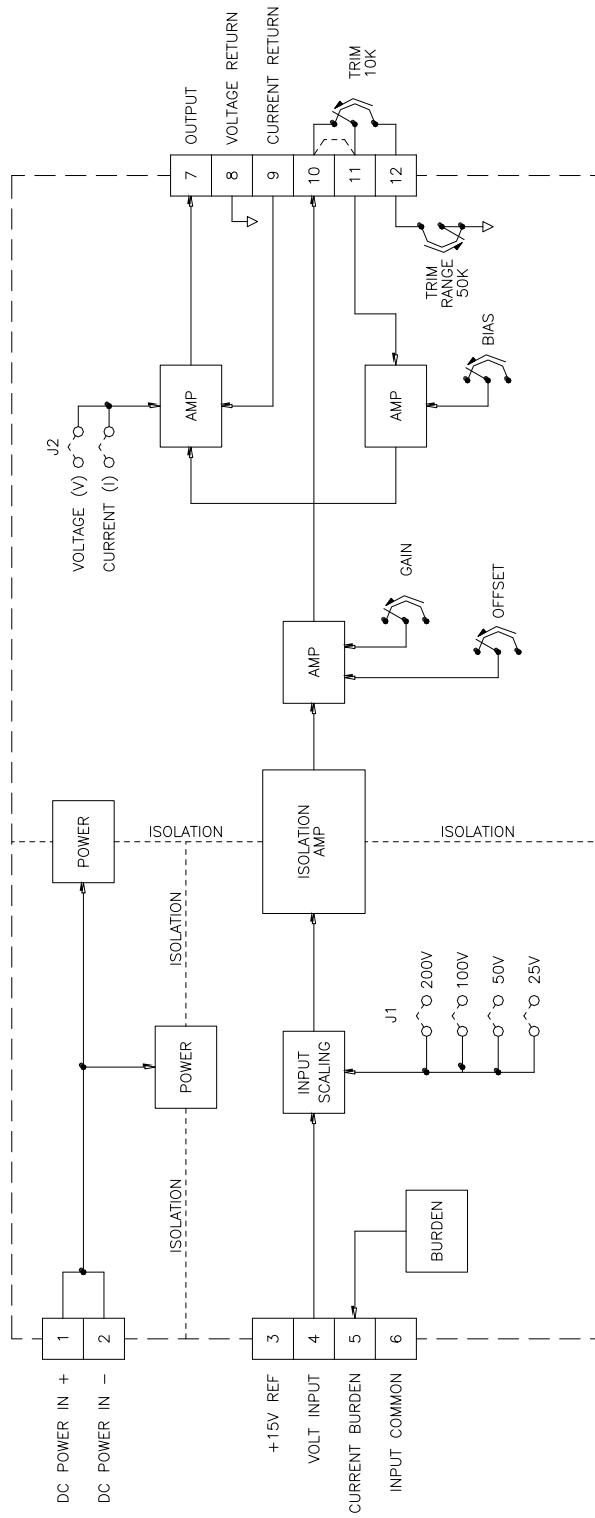

DRAWN BY: BKP DATE: 2/18/2010	APPROVED BY: _____ DATE: _____
TOLERANCES ± 1 DEC. PL. = .001" 2 DEC. PL. = .005" 3 DEC. PL. = .005"	
TITLE: SIM200-000 BLOCK: _____ DIAGRAM: _____	
DRAWING NUMBER: C13661 REV. A SH. 1 OF 1	

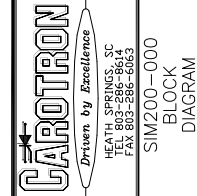

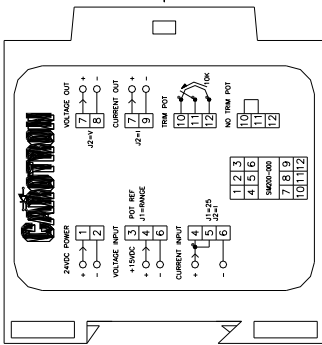
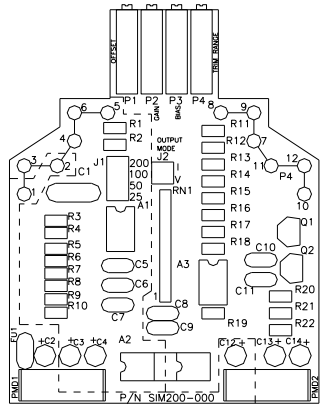
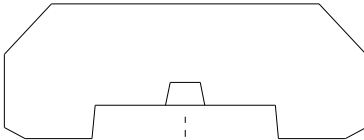
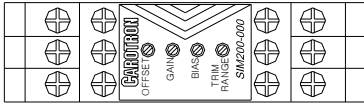
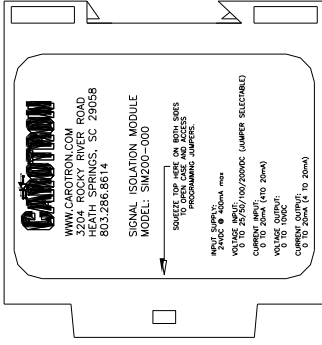

DRAWN BY: BKP DATE: 2/15/10	APPROVED BY: DATE: 	Carotron <i>Driven by Excellence</i> 161 N. SPAINWAY, SC HEATH SPRINGS, SC 29058 TEL: 803-286-8614 FAX: 803-286-8663
TOLERANCES: 1 DEC PL ± .001 2 DEC PL ± .002 3 DEC PL ± .005	TITLE: SIGNAL ISOLATION MODULE ASSEMBLY	SCALE:
DRAWING NUMBER: C13657		REV. A SH. 1 OF 1

POTENTIOMETER INPUT

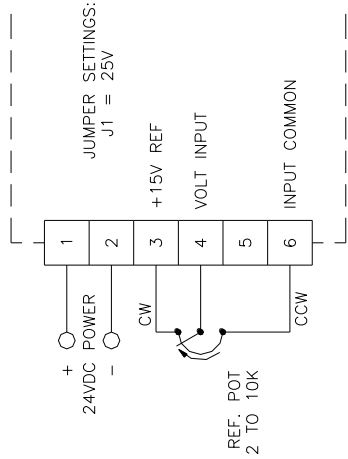

VOLTAGE INPUT

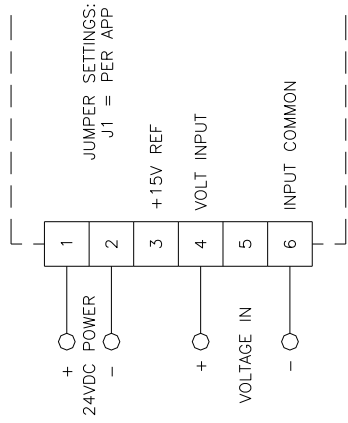

CURRENT INPUT

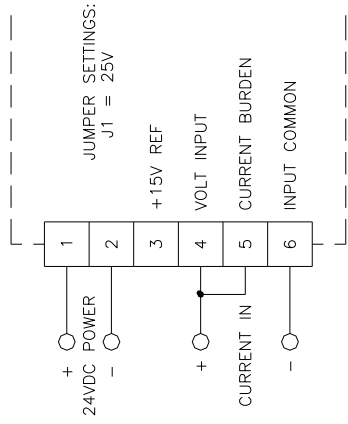

VOLTAGE OUTPUT

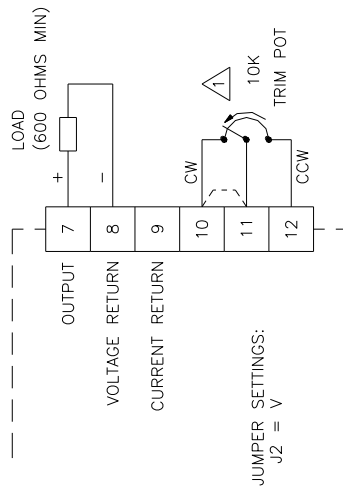

CURRENT OUTPUT

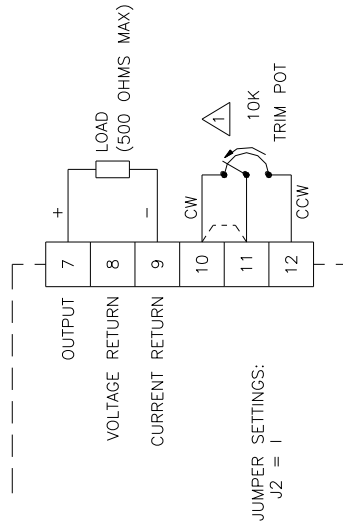

24VDC OUTPUT

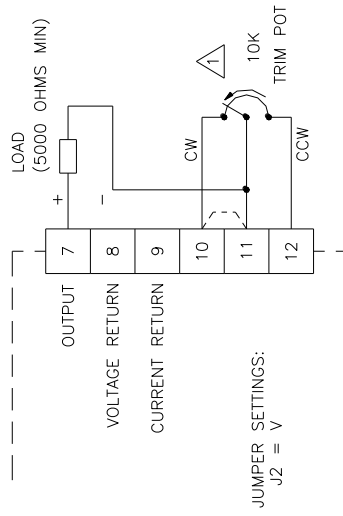

⚠️ JUMPER TERMINALS 10 TO 11 IF TRIM POT IS NOT USED.

DRAWN BY: **BKP**
DATE: **2/16/2010**
APPROVED BY: _____
DATE: _____

TOLERANCES: ±
2 DEC PL. = .010"
3 DEC PL. = .005"

SCALE: _____
TITLE: **SIM200-000 GENERAL CONNECTIONS**

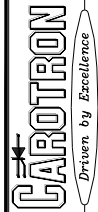

HEATH SPRINGS, SC
TEL 803-286-8614
FAX 803-286-0063

DRAWING NUMBER: **C13660**
REV. **A**
SH. **1** OF **1**

Standard Terms & Conditions of Sale

1. General

The Standard Terms and Conditions of Sale of Carotron, Inc. (hereinafter called "Company") are set forth as follows in order to give the Company and the Purchaser a clear understanding thereof. No additional or different terms and conditions of sale by the Company shall be binding upon the Company unless they are expressly consented to by the Company in writing. The acceptance by the Company of any order of the Purchaser is expressly conditioned upon the Purchaser's agreement to said Standard Terms and Conditions. The acceptance or acknowledgement, written, oral, by conduct or otherwise, by the Company of the Purchaser's order shall not constitute written consent by the Company to addition to or change in said Standard Terms and Conditions.

2. Prices

Prices, discounts, allowances, services and commissions are subject to change without notice. Prices shown on any Company published price list and other published literature issued by the Company are not offers to sell and are subject to express confirmation by written quotation and acknowledgement. All orders of the Purchaser are subject to acceptance, which shall not be effective unless made in writing by an authorized Company representative at its office in Heath Springs, S.C. The Company may refuse to accept any order for any reason whatsoever without incurring any liability to the Purchaser. The Company reserves the right to correct clerical and stenographic errors at any time.

3. Shipping dates

Quotation of a shipping date by the Company is based on conditions at the date upon which the quotation is made. Any such shipping date is subject to change occasioned by agreements entered into previous to the Company's acceptance of the Purchaser's order, governmental priorities, strikes, riots, fires, the elements, explosion, war, embargoes, epidemics, quarantines, acts of God, labor troubles, delays of vendors or of transportation, inability to obtain raw materials, containers or transportation or manufacturing facilities or any other cause beyond the reasonable control of the Company. In no event shall the Company be liable for consequential damages for failure to meet any shipping date resulting from any of the above causes or any other cause.

In the event of any delay in the Purchaser's accepting shipment of products or parts in accordance with scheduled shipping dates, which delay has been requested by the Purchaser, or any such delay which has been caused by lack of shipping instructions, the Company shall store all products and parts involved at the Purchaser's risk and expense and shall invoice the Purchaser for the full contract price of such products and parts on the date scheduled for shipment or on the date on which the same is ready for delivery, whichever occurs later.

4. Warranty

The Company warrants to the Purchaser that products manufactured or parts repaired by the Company, will be free, under normal use and maintenance, from defects in material and workmanship for a period of one (1) year after the shipment date from the Company's factory to the Purchaser. The Company makes no warranty concerning products manufactured by other parties.

As the Purchaser's sole and exclusive remedy under said warranty in regard to such products and parts, including but not limited to remedy for consequential damages, the Company will at its option, repair or replace without charge any product manufactured or part repaired by it, which is found to the Company's satisfaction to be so defective; provided, however, that (a) the product or part involved is returned to the Company at the location designated by the Company, transportation charges prepaid by the Purchaser; or (b) at the Company's option the product or part will be repaired or replaced in the Purchaser's plant; and also provided that (c) the Company is notified of the defect within one (1) year after the shipment date from the Company's factory of the product or part so involved.

The Company warrants to the Purchaser that any system engineered by it and started up under the supervision of an authorized Company representative will, if properly installed, operated and maintained, perform in compliance with such system's written specifications for a period of one (1) year from the date of shipment of such system.

As the Purchaser's sole and exclusive remedy under said warrant in regard to such systems, including but not limited to remedy for consequential damages, the Company will, at its option, cause, without charges any such system to so perform, which system is found to the Company's satisfaction to have failed to so perform, or refund to the Purchaser the purchase price paid by the Purchaser to the Company in regard thereto; provided, however, that (a) Company and its representatives are permitted to inspect and work upon the system involved during

reasonable hours, and (b) the Company is notified of the failure within one (1) year after date of shipment of the system so involved.

The warranties hereunder of the Company specifically exclude and do not apply to the following:

a. Products and parts damaged or abused in shipment without fault of the Company.

b. Defects and failures due to operation, either intentional or otherwise, (1) above or beyond rated capacities, (2) in connection with equipment not recommended by the Company, or (3) in an otherwise improper manner.

c. Defects and failures due to misapplication, abuse, improper installation or abnormal conditions of temperature, humidity, abrasives, dirt or corrosive matter.

d. Products, parts and systems which have been in any way tampered with or altered by any party other than an authorized Company representative.

e. Products, parts and systems designed by the Purchaser.

f. Any party other than the Purchaser.

The Company makes no other warranties or representation, expressed or implied, of merchantability and of fitness for a particular purpose, in regard to products manufactured, parts repaired and systems engineered by it.

5. Terms of payment

Standard terms of payment are net thirty (30) days from date of the Company invoice. For invoice purposed, delivery shall be deemed to be complete at the time the products, parts and systems are shipped from the Company and shall not be conditioned upon the start up thereof. Amounts past due are subject to a service charge of 1.5% per month or fraction thereof.

6. Order cancellation

Any cancellation by the Purchaser of any order or contract between the Company and the Purchaser must be made in writing and receive written approval of an authorized Company representative at its office in Heath Springs, S.C. In the event of any cancellation of an order by either party, the Purchaser shall pay to the Company the reasonable costs, expenses, damages and loss of profit of the Company incurred there by, including but not limited to engineering expenses and expenses caused by commitments to the suppliers of the Company's subcontractors, as determined by the Company.

7. Changes

The Purchaser may, from time to time, but only with the written consent of an authorized Company representative, make a change in specifications to products, parts or systems covered by a purchase order accepted by the company. In the event of any such changes, the Company shall be entitled to revise its price and delivery schedule under such order.

8. Returned material

If the Purchaser desires to return any product or part, written authorization thereof must first be obtained from the Company which will advise the Purchaser of the credit to be allowed and restocking charges to be paid in regard to such return. No product or part shall be returned to the Company without a "RETURN TAG" attached thereon which has been issued by the Company.

9. Packing

Published prices and quotations include the Company's standard packing for domestic shipment. Additional expenses for special packing or overseas shipments shall be paid by the Purchaser. If the Purchaser does not specify packing or accepts parts unpacked, no allowance will be made to the Purchaser in lieu of packing.

10. Standard transportation policy

Unless expressly provided in writing to the contrary, products, parts and systems are sold f.o.b. first point of shipment. Partial shipments shall be permitted, and the Company may invoice each shipment separately. Claims for non-delivery of products, parts and systems, and for damages thereto must be filed with the carrier by the Purchaser. The Company's responsibility therefor shall cease when the carrier signs for and accepts the shipment.



CAROTRON

Driven by Excellence

D.C. DRIVES, A.C. INVERTERS,
SOLID STATE STARTERS, SYSTEM INTERFACE
CIRCUITS AND ENGINEERED SYSTEMS

3204 Rocky River Road
Heath Springs, SC 29058
Phone: 803.286.8614
Fax: 803.286.6063
Email: saleserv@carotron.com
Web: www.carotron.com
MAN1052-00 Rev. C
Issued 08-27-2015